



Operation **Manual**

Goodrive300-21 series Dual-inverter
Integrated Machine for Air Compressor



SHENZHEN INVT ELECTRIC CO., LTD.

Preface

Goodrive300-21 series dual inverter integrated machine for air compressor (hereafter referred to as Goodrive300-21 air compressor integrated machine) is especially developed for synchronous / asynchronous twin screw air compressor. It can be used in combination with VT6070E series touch screen to drive and control the twin screw air compressor.

Goodrive300-21 air compressor integrated machine is capable of providing dual inverter output of master and fan for the air compressor as well as offering +24V power to the touch screen. It supports control of solenoid valve and receiving of temperature and pressure signal. In respect of function, it is a perfect replacement for the original dual inverter electrical control cabinet of air compressor but with a much smaller size and simpler installation and debugging procedures.

Given the application scenarios and actual demands of air compressor, Goodrive300-21 air compressor integrated machine can realize fast start-up and stable operation of air compressor through dual PID and unique weak magnetic design. It adopts independent air duct, heavy load and high power factor design to effectively cope with challenging grid conditions and application environment. In addition, it can realize IOT function and accurate power detection by installing optional parts and accessories.

Read through this manual carefully before installation to ensure correct installation and operation of Goodrive300-21 air compressor integrated machine, thus giving full play to its excellent functions and performance.

If the product is ultimately used for military affairs or manufacture of weapon, it will be listed on the export control formulated by Foreign Trade Law of the People's Republic of China. Rigorous review and necessary export formalities are needed when exported.

Our company reserves the right to update the information of our products.

Contents

Preface	i
Content	ii
1. Product overview	1
1.1. Product specification	1
1.2. Product nameplate	2
1.3. Type designation	2
1.4. Rated value	3
2. Installation guidance	4
2.1. Wiring and terminal instruction of main circuit	4
2.2. Control circuit connection and terminal instruction	5
3. Instruction for panel display	10
4. Debugging guidance	11
4.1. Wiring diagram of integrated machine system	11
4.2. Recommended layout process	11
4.3. Function debugging procedures	14
5. Function instruction	22
5.1. Function code instruction	22
5.3. Instruction of air compressor control logic	57
6. Fault information and solution	60
6.1. Faults and countermeasures for integrated machine	60
6.2. Fault and countermeasures for air compressor device	65
Appendix A. Product dimension	68
A.1. Wall installation dimension	68
A.2. Floor installation dimension (with top cover)	69
A.3. Floor installation dimension (without top cover)	70
A.4. Product weight and packaging dimension	70
Appendix B. Optional parts and accessories	72
B.1. Power consumption component	72
B.2. Contactor component	76
B.3. Power detection component and contactor component	78
B.4. Remote data collection terminal component	79
B.5. Drip-proof top cover	81
B.6. Floor installation pedestal	83
B.7. Touch screen	86
Appendix C. Communication protocol	88
C.1. Application mode of the inverter	88
C.2. RTU command code and communication data illustration	88
Appendix D. Common EMC problems and countermeasures	95
D.1. Interference problems of meter switch and sensors	95
D.2. 485 communication interference	95
D.3. Unstoppable or shimmering indicator caused by coupling of motor cable	96
D.4. Leakage current and residual current device (RCD)	97
D.5. Problem of charged device shell	98

1. Product overview

Goodrive300-21 air compressor integrated machine is capable of providing dual inverter output of master and fan to the air compressor and offering +24V power to the touch screen. It supports control of solenoid valve and receiving of temperature and pressure signal. In respect of function, it is a perfect replacement for the original dual inverter electrical control cabinet of air compressor but with a much smaller size and simpler installation and commissioning procedures.

1.1. Product specification

Category	Function	Specification
Power input	Input voltage of inverter (V)	3PH 220V(-15%)–240V(+10%) 3PH 380V(-15%)–440V(+10%)
	Rated input current (A)	Please refer to “1.4 Rated value”
	Rated input frequency(Hz)	50Hz or 60Hz; allowed range: 47–63Hz
	Efficiency	> 97%
	Power factor	0.9
Power output of main inverter	Output voltage (V)	Equal to input voltage and the error is less than 5%
	Rated output current (A)	Please refer to “1.4 Rated value”
	Rated output power (kW)	Please refer to “1.4 Rated value”
	Output frequency (Hz)	0–400Hz
Power output of fan inverter	Output voltage (V)	Equal to input voltage and the error is less than 5%
	Rated output current (A)	Please refer to “1.4 Rated value”
	Rated output power (kW)	Please refer to “1.4 Rated value”
	Output frequency (Hz)	0–50Hz
Other power output	+24VDC power	24W
	220VAC/110VAC	30W
Running control performance	Control mode	Open loop vector, space voltage vector
	Speed ratio	Asynchronous motor: 1:200 (SVC), synchronous motor: 1:20 (SVC)
	Speed control precision	±0.2% (SVC)
	Speed fluctuation	±0.3% (SVC)
	Torque response	<20ms (SVC)
	Starting torque	Asynchronous motor : 0.25Hz 150% (SVC) Synchronous motor: 2.5Hz 150% (SVC)
	Overload capacity	Master inverter: 150%/1m Fan inverter: 120%/1m
	Specialized function	Sleep and wake-up function, constant pressure control, constant temperature control, accessory maintenance and phase sequence inspection

Category	Function	Specification
	Analog input of pressure	Two-channel 4–20mA/0–1.6MPa input
	Analog input of temperature	Two-channel temperature analog input; resolution rate: 1℃, range: -20℃–150℃
	Digital input	Five-channel normal input; max. frequency: 1kHz
	Digital output	One-channel Y terminal output, two-channel relay output (NO) 250VAC/3A
	Fault protection function	Provide over 30 kinds of fault protection function: overcurrent, overvoltage, undervoltage, over-temperature, phase-loss and overload.
	Communication 485	One-channel 485 communication (two terminal interfaces)
Others	Installation mode	Wall or floor installation
	Running environment	-10–50℃, derate when temperature is over 40℃, derate 1% for each additional 1℃.
	Protection class	IP20
	Pollution level	Level 2
	Cooling mode	Forced air cooling
	DC reactor	Standard configuration
	EMC filter	Optional external filter: meet IEC61800-3 C2 requirement.

Note: When the voltage of the integrated machine is above 440VAC, the power frequency transformer inside the integrated machine needs to be customized as needed.

1.2. Product nameplate

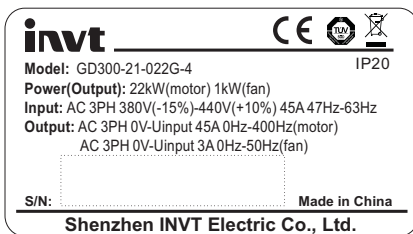

Fig 1.1 Product nameplate

Note: This is just an example of Goodrive300-21 nameplate, in which the CE/TUV/IP20 part will be marked according to actual certification conditions.

1.3. Type designation

GD300-21 – 022 G – 4

① ② ③ ④

Fig 1.2 Product model

Field	Symbol	Instruction	Detailed description
Abbreviation of product series	①	Abbreviation of product series	Goodrive300-21: GD300-21 series dual inverter integrated machine for air compressor
Rated power	②	Power class	022: 22kW
Load type	③	Load type	G: Constant torque load
Voltage class	④	Voltage class	2: AC 3PH 220V(-15%)–240V(+10%) 4: AC 3PH 380V(-15%)–440V(+10%)

1.4. Rated value

Model	Rated input current of the integrated machine (A)	Main motor inverter		Fan inverter	
		Rated output power (kW)	Rated output current (A)	Rated output power (kW)	Rated output current (A)
GD300-21-7R5G-2	35	7.5	30	1	4.2
GD300-21-011G-2	48	11	42	1	4.2
GD300-21-015G-2	60	15	55	1	4.2
GD300-21-018G-2	75	18.5	70	1	4.2
GD300-21-022G-2	90	22	80	1.5	7.5
GD300-21-030G-2	120	30	110	1.5	7.5
GD300-21-037G-2	145	37	130	1.5	7.5
GD300-21-045G-2	175	45	160	3	11
GD300-21-015G-4	33	15	32	1	3
GD300-21-018G-4	38	18.5	38	1	3
GD300-21-022G-4	45	22	45	1	3
GD300-21-030G-4	60	30	60	1.5	3.7
GD300-21-037G-4	75	37	75	1.5	3.7
GD300-21-045G-4	93	45	92	3	6.8
GD300-21-055G-4	112	55	115	3	6.8
GD300-21-075G-4	146	75	150	3	6.8
GD300-21-090G-4	175	90	180	4	9.5

Note:

1. The rated input current of 15–90kW integrated machine is the actual result gained under 380V input voltage.
2. The rated output current is defined as the output current under 380V output voltage.

2. Installation guidance

2.1. Wiring and terminal instruction of main circuit

2.1.1. Wiring diagram of main circuit

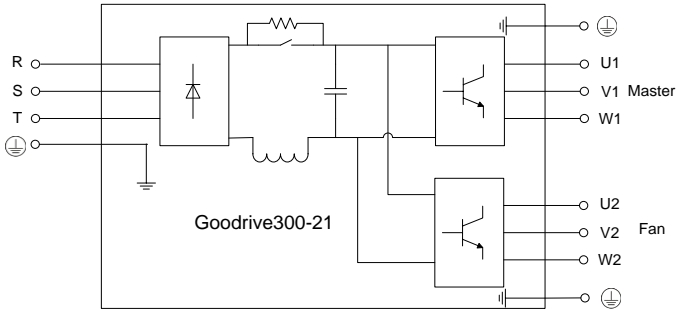

Fig 2.1 Wiring diagram of main circuit

2.1.2. Terminal diagram of main circuit

The terminal layout of 15–22kW, 30kW–37kW and 45–90kW main circuit slightly differs from each other. In below figure, 15–22kW and 45–90kW models are taken as examples for terminal layout.

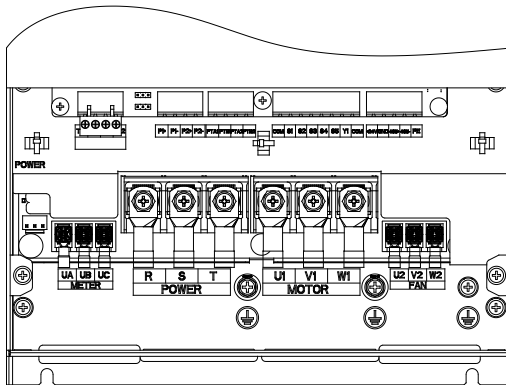

Fig 2.2 Terminal layout of 15–22kW

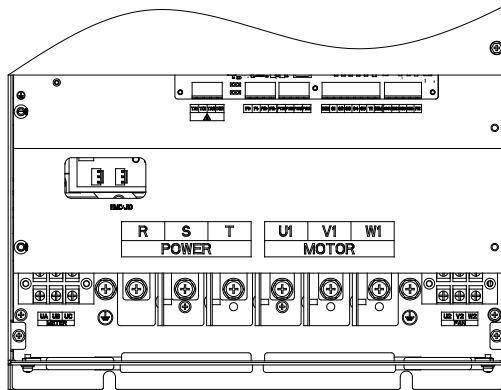

Fig 2.3 Terminal layout of 45–90kW

Table 2.1 Terminal instruction

Terminal symbol	Terminal function
UA, UB, UC	1. Used for voltage sampling connection of optional power detection components. 2. Used for input connection of optional contactor components.
R, S, T	3PH AC input terminal, connected to the grid
U1, V1, W1	3PH AC output terminal, connected to main motor of air compressor
U2, V2, W2	3PH AC output terminal, connected to the fan
⊕	Grounding terminal of safety protection, each machine must be grounded.

Note:

1. Do not use asymmetrically constructed motor cable. If there is a symmetrically constructed ground conductor in the motor cable in addition to the conductive shielding layer, ground the ground conductor at the inverter end and motor end.
2. Lay the motor cable, input power cable, and control cable separately.
3. Before powering on the system, ensure that U1/V1/W1 or U2/V2/W2 are not short-circuited to PE on the output side. Otherwise, tripping may occur on the power distribution cabinet when the system is being powered on.

2.2. Control circuit connection and terminal instruction

2.2.1. Control circuit layout diagram

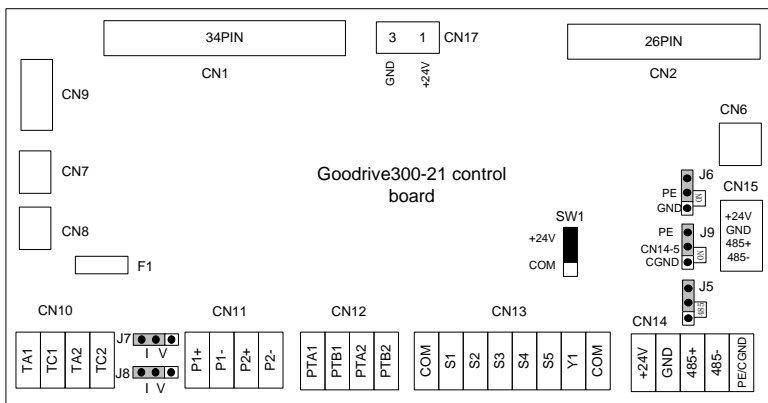

Fig 2.4 Control circuit layout diagram

Table 2.2 Terminal instruction

Terminal symbol	Name	Remark
CN1	Flat cable interface	Connected to drive board, master control signal wire
CN17	Power interface	Outputs +24V power, can be used to power up external GPRS.
CN2	Flat cable interface	Connected to drive board, fan control signal wire
CN6	Keypad interface	Reserved interface, connected with keypad
CN15	Power detection interface	Connected to power detection module, provides +24V power and 485 communication interface
CN14	Touch screen interface	Connected to touch screen, provide +24V power and 485 communication interface
CN13	Digital input terminal	Multi-function input terminal
CN12	Temperature detection terminal	Connected to PT100 temperature sensor
CN11	Pressure detection terminal	Connected to pressure sensor
CN10	Relay output terminal	Connected to solenoid valve or contactor coil
F1	Fuse (0.6A/250VAC)	Short circuit of solenoid valve/contacter coil terminal or overcurrent protection
CN9	220V/110V voltage input terminal	Connected to internal power frequency transformer
CN7	220V voltage	Select this terminal with jumpers when users select the solenoid

Terminal symbol	Name	Remark
	selection terminal	valve with 220V coil or the contactor. Note: The default selection is 220V voltage terminal
CN8	110V voltage selection terminal	Select this terminal with jumpers when users select the solenoid valve with 110V coil or the contactor.
J5	Access terminal for 485 communication terminal resistor	485 corresponds to access terminal resistor. Does not connect terminal resistor by default.
J6	Short-circuit terminal of PE and GND	ON corresponds to short-circuit. No short circuit by default
J7	Jumper terminal	Corresponds to P1+, P1- pressure analog signal selection. I corresponds to current signal, V to voltage signal. The default is current input signal.
J8	Jumper terminal	Corresponds to P2+, P2- pressure analog signal selection. I corresponds to current signal, V to voltage signal. The default is current input signal.
J9	PE/CGND selection terminal	485 communication is non-isolation mode. CN14-5 is short circuited with PE by default.
SW1	Toggle switch	Set to +24V terminal by default. See details at fig 2.5 and fig 2.6.

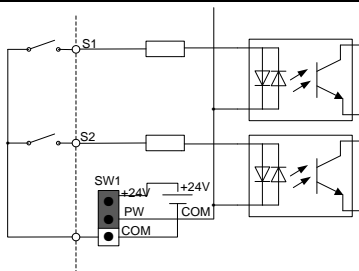

Fig 2.5 Internal power (NPN mode)

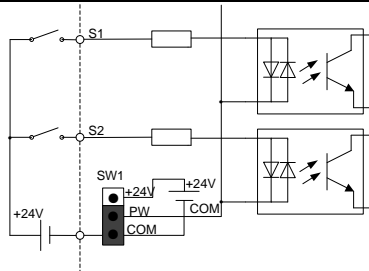

Fig 2.6 External power (PNP mode)

When digital input adopts internal +24V, set the toggle switch according to fig. 2.5 and short circuit +24V with PW. When digital input adopts external +24V, set the toggle switch according to fig 2.6 and short circuit COM with PW.

2.2.2. Wiring diagram of control circuit

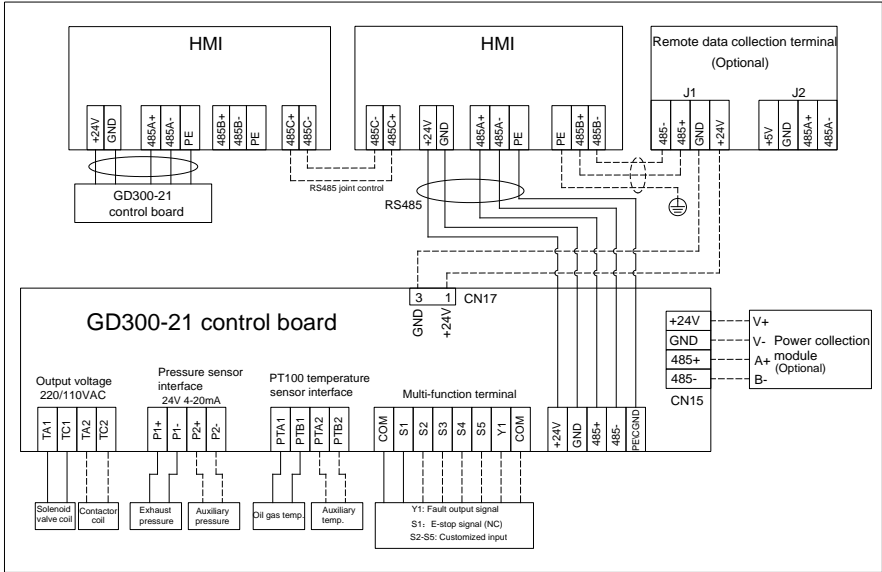

Fig 2.7 Wiring diagram of control circuit

Note: The solid line represents the recommended wiring diagram which carries the least wiring for ensuring system operation. The dotted line represents the wiring diagram used when discrepancy occurred to the configuration of integrated machine.

2.2.3. User terminal instruction of control circuit

Table 2.3 User terminal instruction of control circuit

Category	Terminal symbol	Terminal name	Terminal function
Power	+24V	+24V power	Provide +24V±5% power to the external; max. output current 1A. Used for powering up GPRS, touch screen, power detection module
	GND	+24V power GND	+24V power reference GND
PT100 signal input	PTA1	Temperature analog signal 1	1. Resolution rate: 1℃ 2. Range: -20℃–150℃ 3.: Detection precision: 3℃
	PTB1		
	PTA2	Temperature analog signal 2	
	PTB2		
Pressure signal input	P1+	Pressure analog signal 1	1. Input range: Current and voltage is optional, 4–20mA/2–10V corresponds to 0–1.6MPa; P1 is
	P1-		

Category	Terminal symbol	Terminal name	Terminal function
	P2+	Pressure analog signal 2	switched by jumper J7 while P2 by J8 2. Input impedance: 20kΩ during voltage input and 500Ω during current input 3. Resolution rate: min. 5mV 4. Error: ±1%, 25℃
	P2-		
Digital input	S1	Digital input 1	1. Internal impedance: 3.3 kΩ 2. 12–30V voltage input is acceptable 3. Max. input frequency: 1kHz
	S2	Digital input 2	
	S3	Digital input 3	
	S4	Digital input 4	
	S5	Digital input 5	
	COM	Digital reference GND	
Digital output	Y1	Digital output	1. Contact capacity: 200mA/30V 2. Output frequency range: 0–1kHz
Communication	485+, 485-	485 communication	485 communication terminal, adopt Modbus RTU protocol
PE/CGND	PE/CGND		PE: When select PE by J9, it can be used in connection terminal of 485 communication shielded cable; CGND: When select CGND by J10, it can be used in connection terminal of 485 communication reference GND or shielded cable.
Solenoid valve	TA1	Solenoid valve coil	1. Contact capacity: 3A/AC250V, 1A/DC30V 2. Cannot used as high frequency switch output (NOTE) 3. Voltage of power supply: 220V/110V, select via CN7/CN8 4. Max. output power of internal power frequency transformer: 30W
	TC1		
	TA2	Contactor coil	
	TC2		

Note: The connection terminal of solenoid valve/contacter cannot be connected to other load. When the power of solenoid valve and contactor coil exceeds 30W, the power frequency transformer inside the integrated machine needs to be customized or connected with external 220V power independently.

3. Instruction for panel display

The panel of Goodrive300-21 series air compressor integrated machine carries three LED indicators (fault, running, power). The position and display state of the indicators are illustrated as below:

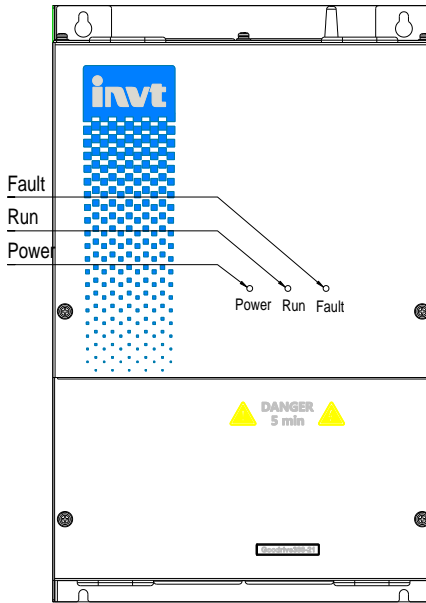

Fig 3.1 Diagram of indicator position

Display state of indicators		State instruction
Power indicator (green)	ON	Bus voltage is normal
	Flash	Bus voltage is abnormal
Running indicator (green)	ON	Running
	OFF	Stop
Fault indicator (read)	ON	Fault
	OFF	Normal running

4. Debugging guidance

4.1. Wiring diagram of integrated machine system

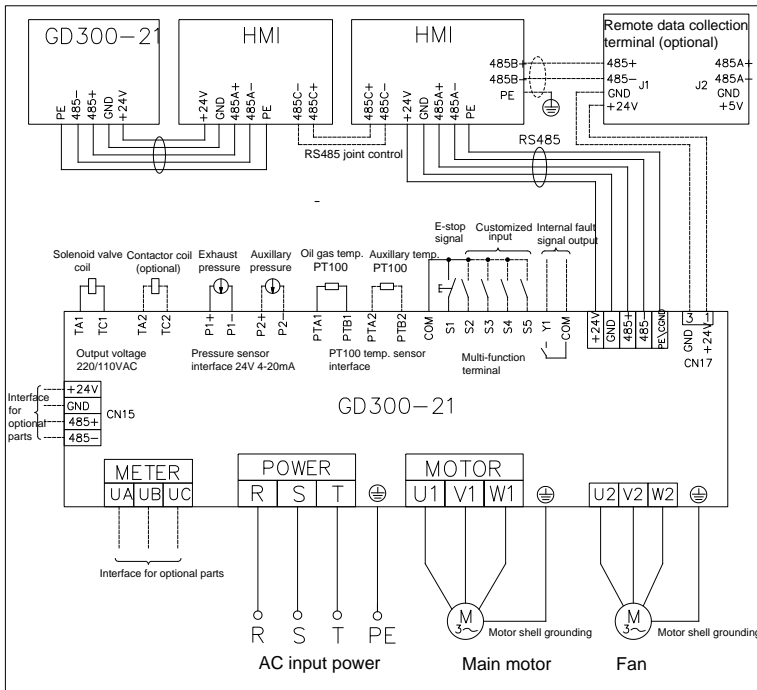

Fig 4.1 Wiring diagram of integrated machine system

Note: The solid line represents the recommended wiring diagram which carries the least wiring for ensuring system operation. The dotted line represents the wiring diagram used when discrepancy occurred to the configuration of integrated machine.

4.2. Recommended layout process

The terminal layout of 15–22kW, 30kW–37kW and 45–90kW slightly differs from each other. 15–22kW and 45–90kW are taken as examples for terminal layout.

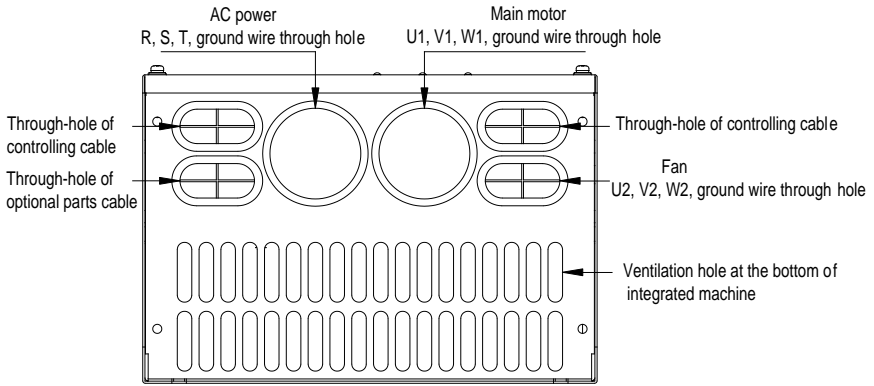

Fig 4.2 Bottom view for 15–22kW

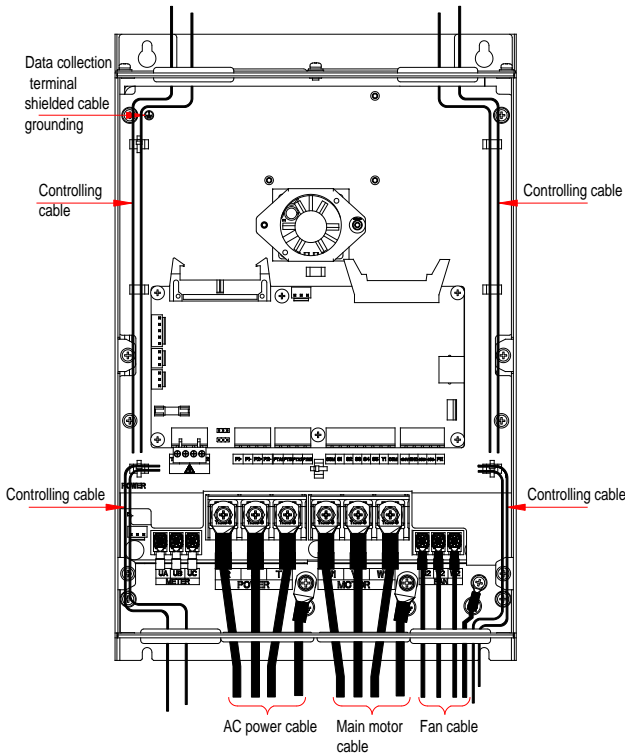

Fig 4.3 Front wiring diagram for 15–22kW

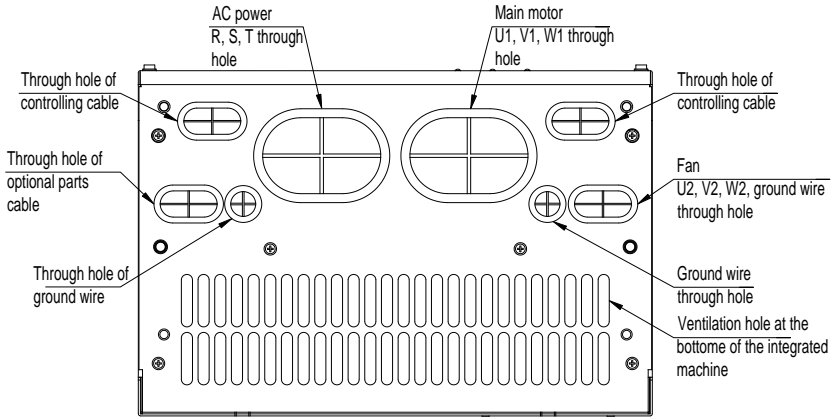

Fig 4.4 Bottom view for 45–90kW

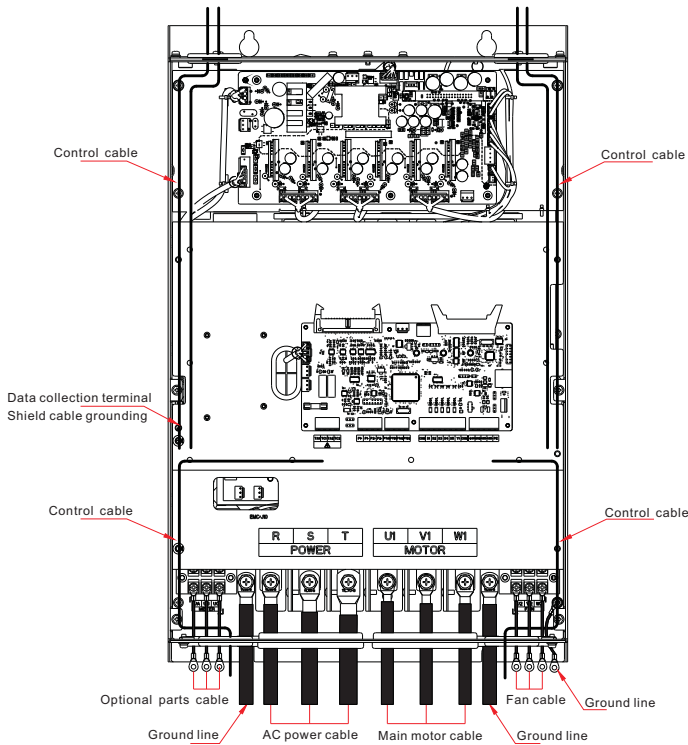

Fig 4.5 Front wiring diagram for 45–90kW

Note:

1. There are two controlling cable through holes on the top and at the bottom of the integrated machine cabinet, users can select which through-hole to use based on wiring condition. It is recommended that the controlling cable is routed via top through-hole to realize separation between controlling cable and motor cable and reduce interference. The motor temperature detection or temperature protection cable which follows the motor power cable can be routed via bottom through-hole.
2. Refer to B.6.3 for floor installation layout.

4.3. Function debugging procedures

It is recommended that Goodrive300-21 air compressor integrated machine adopt touch screen for displaying and commissioning. The concrete procedures are listed as below: (if other controllers are used, contact our technician)

1. Conduct wiring and routing according to Fig 4.1 and Fig 4.2; check carefully if the wiring is correct and ensure the integrated machine and its shell GND is properly connected;
2. After power on, the touch screen HMI interface is shown as below:

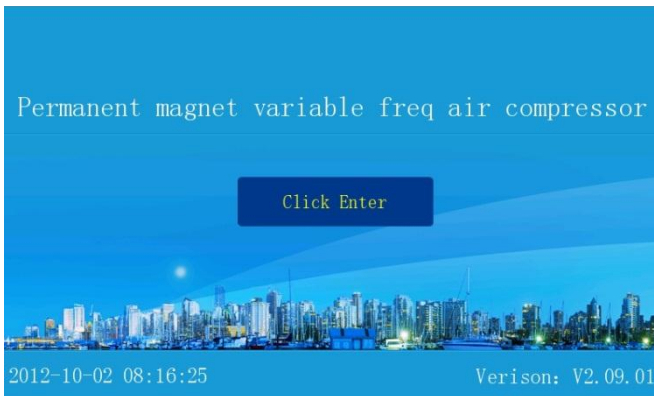

Fig 4.6 Log-in interface

3. Click “click to enter” and enter working environment interface:

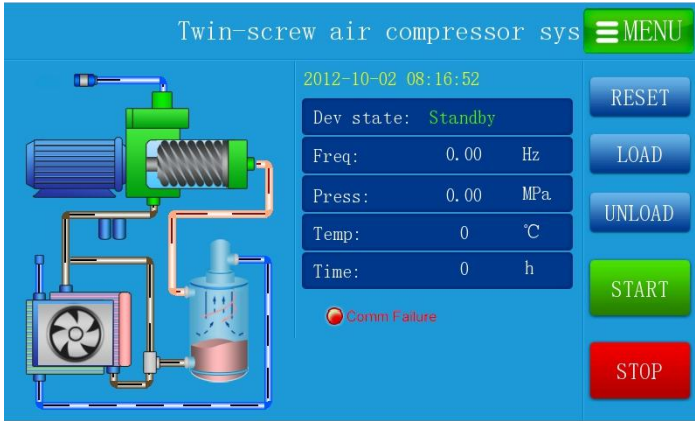

Fig 4.7 Working interface

4. Click “menu” in above interface and the interface is as below:

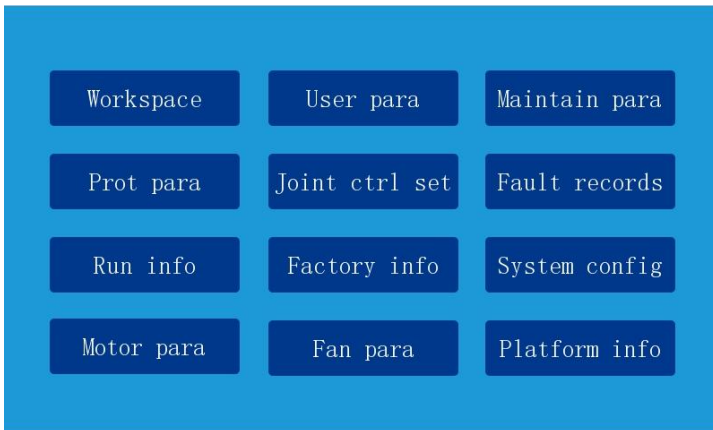

Fig 4.8 Menu interface

5. Click “system config” in touch screen menu and enter system configuration page, the interface is shown as below:

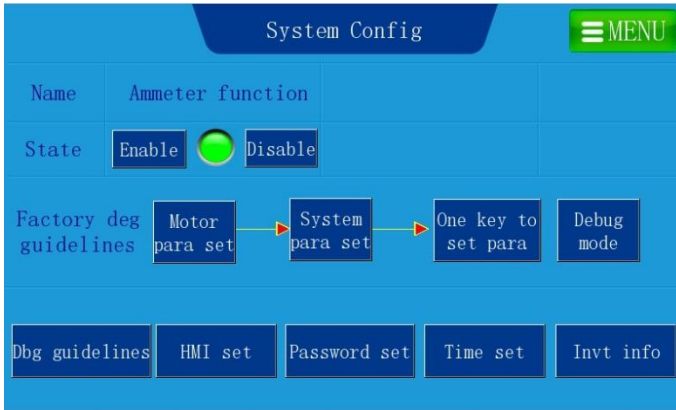

Fig 4.9 System configuration interface

The fan inverter is enabled by default. Debug according to the debugging procedures.

Step 1: Click “Dbg guidelines” in system configuration interface and the interface is as below:

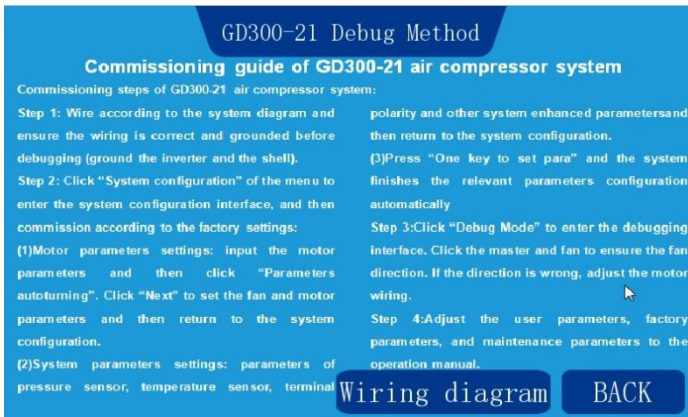

Fig 4.10 Debugging guidance interface

After read through above procedures, click “BACK” to enter system configuration.

Step 2: Click “motor para set” in system configuration interface and the interface is shown as below:

Select motor type, if select “synchronous motor”, it is necessary to set the max. frequency, rated frequency, rated power, rated voltage, rated current, number of pole pairs, carrier frequency; if select

“asynchronous motor, it is necessary to set max. frequency, rated frequency, rated power, rated voltage, rated current, rated rotation speed and carrier frequency.

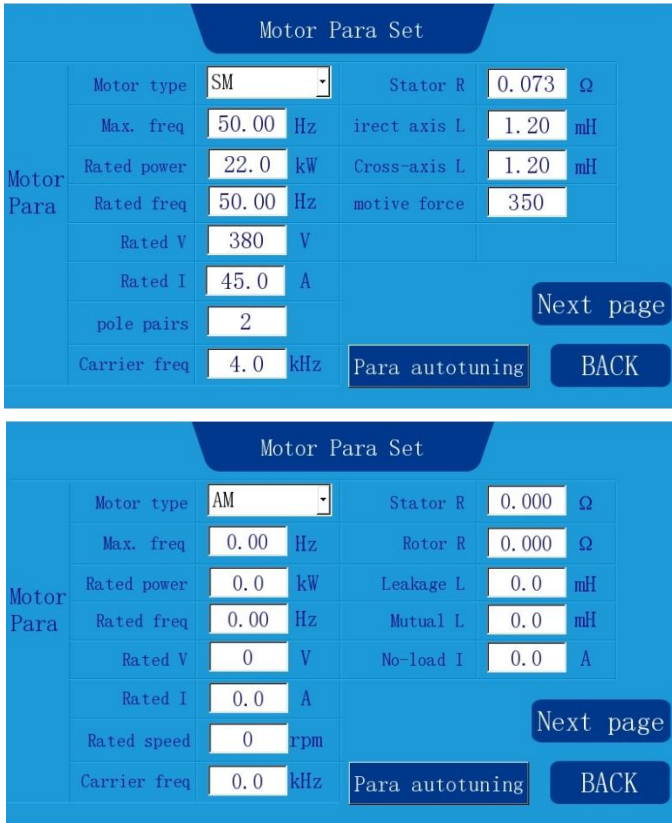

Fig 4.11 Master parameter setting interface

After setting motor parameters according to actual motor nameplate parameters, click “para autotuning” and after recognition completes, click “Next page” and set fan motor parameter (it is necessary to set the max. frequency, rated frequency, rated power, rated voltage, rated current and rated rotation speed.)

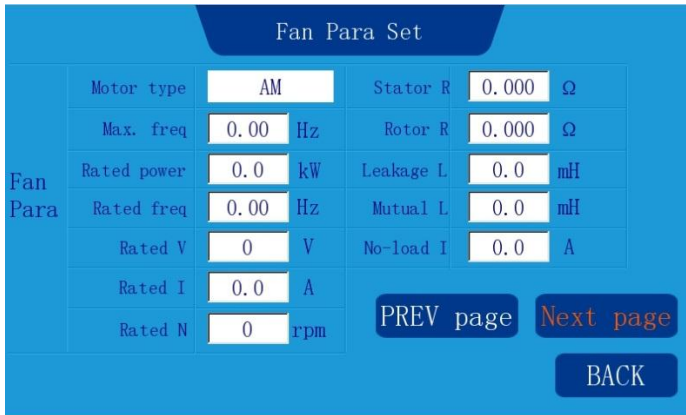

Fig 4.12 Interface for setting fan parameters

Step 3: Click “Next page” to enter “system parameter configuration” or click “BACK” to return to system configuration. In system configuration interface, click “system para set”. S1 acts as E-stop switch and select NO/NC according to the polarity of E-stop switch. The interface is shown as below:

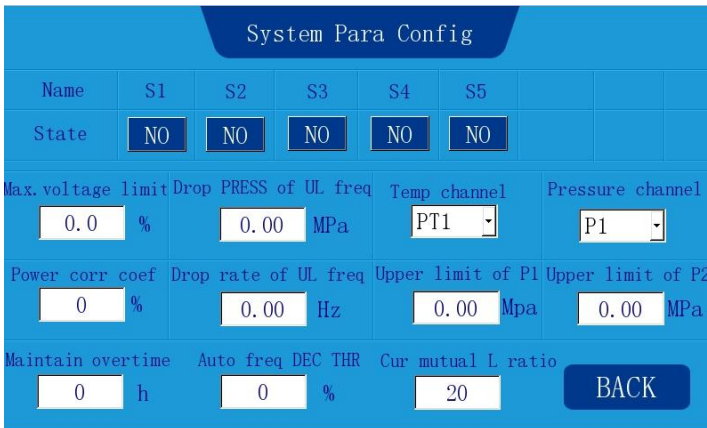

Fig 4.13 System parameter configuration interface

Set pressure sensor parameter, temperature sensor parameter and specialized function parameter according to system sensor configuration condition. Then, click “BACK” to enter system configuration page.

Step 4: In system configuration interface, click “one-key to set para” button and the system will complete relevant parameter configuration automatically.

Step 5: In system configuration interface, click “debug mode” and the interface is shown as below:

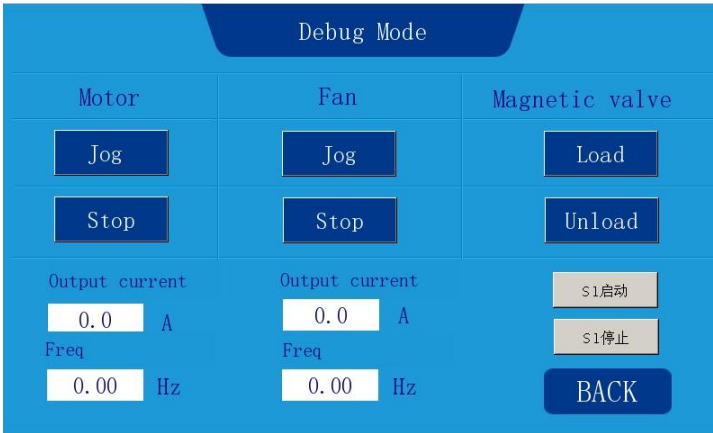

Fig 4.14 Debugging mode interface

Click “jog” for motor and fan to determine motor rotation direction; click “load” or “unload” to test the action of solenoid valve. Click “BACK” to enter system configuration, then, click “menu” to return menu interface.

6. Click “user para” in touch screen menu and the interface is shown as below:

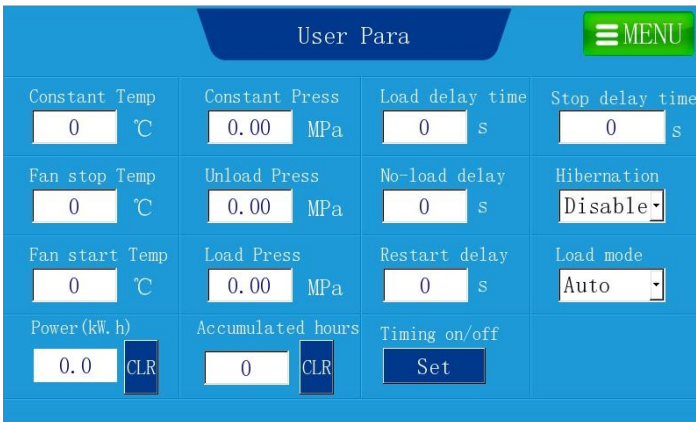

Fig 4.15 User parameter interface

7. Click “maintenance para” in touch screen menu and the interface is shown as below:

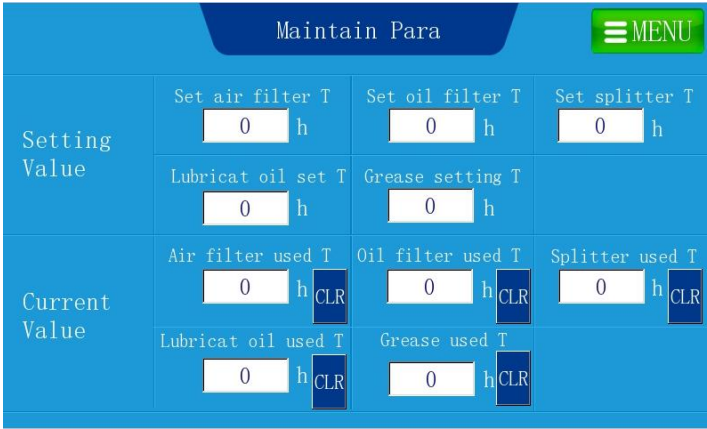

Fig 4.16 Maintenance parameter interface

8. Click “protection para” in the menu and the interface is shown as below:



Fig 4.17 Protection parameter interface

9. Click “running info” in the menu and the interface is shown as below:

Running Info				Power curve	Pressure curve	Temp curve	MENU
Motor Running Info	Output current	0.0 A	Output voltage	0 V	Rotating speed	0 rpm	
	Frequency	0.00 Hz	Power	0.0 kW	Pressure	0.00 MPa	
Fan Running Info	Fan state	Stop	Temperature	0 °C	Rotating speed	0 rpm	
	Output current	0.0 A	Output voltage	0 V	Frequency	0.00 Hz	

Fig 4.18 Running information interface

10. After adjusting user parameter, factory parameter, maintenance parameter according to touch screen manual, return to “workspace” interface and click “start” to run.

Note: All the parameters displayed in “4.3 function debugging procedures” are for reference only and subject to actual displayed content.

5. Function instruction

“○” : means the setting value of this parameter is modifiable when the inverter is in stop and running state;

“⊙” : means the setting value of this parameter is non-modifiable when the inverter is in running state;

“●” : means the value of this parameter is the actual detected record value and cannot be modified.

(The modification attribute of each parameter has been limited automatically to avoid mal-operation by users.)

5.1. Function code instruction

Function code	Name	Detailed instruction	Default value	Modify
P00.00	Speed control mode	0: SVC 0 (suitable for AM, SM) 1: SVC 1 (suitable for AM) 2: V/F control Note: AM-asynchronous motor SM-synchronous motor If vector mode is adopted, it is necessary to carry out motor parameter autotuning first.	0	⊙
P00.01	Running command channel	0: Keypad running command channel (LED off) 1: Terminal running command channel (LED flashes) 2: Communication running command channel (LED on)	0	○
P00.02	Communication running command channel selection	0: MODBUS communication channel 1–3: Reserved	0	○
P00.03	Max. output frequency	P00.04–600.00Hz (400.00Hz)	50.00Hz	⊙
P00.04	Upper limit of running frequency	P00.05–P00.03 (Max. output frequency) Setting range: P00.06–P00.03	50.00Hz	○
P00.05	Lower limit of running frequency	0.00Hz–P00.04 (upper limit of running frequency)	0.00Hz	○

Function code	Name	Detailed instruction	Default value	Modify
P00.06	A frequency command selection	0: Keypad digital setting 1: Analog P1-setting	0	<input type="radio"/>
P00.07	B frequency command selection	2: Reserved 3: Analog P2-setting 4: Reserved 5: Reserved 6: Multi-step speed running setting 7: PID control setting 8: MODBUS communication setting 9–11: Reserved Note: A frequency and B frequency cannot be set to the same frequency reference mode. Frequency source can be set by P00.09	2	<input type="radio"/>
P00.08	Reference object of B frequency command	0: Max. output frequency 1: A frequency command	0	<input type="radio"/>
P00.09	Combination mode of setting source	0: A 1: B 2: (A+B) combination 3: (A-B) combination 4: Max (A, B) combination 5: Min (A, B) combination	0	<input type="radio"/>
P00.10	Keypad setting frequency	0.00 Hz–P00.03 (Max. output frequency)	50.00Hz	<input type="radio"/>
P00.11	Acceleration time 1	0.0–3600.0s	Depend on model	<input type="radio"/>
P00.12	Deceleration time 1	0.0–3600.0s	Depend on model	<input type="radio"/>
P00.13	Running direction selection	0: Run by the default direction 1: Run by the reverse direction 2: Reverse running is prohibited	2	<input type="radio"/>
P00.14	Carrier frequency setting	1.0–15.0kHz	Depend on model	<input type="radio"/>
P00.15	Motor parameter autotuning	0: No operation 1: Rotary autotuning 2: Static autotuning 1 (all-around autotuning)	0	<input checked="" type="radio"/>

Function code	Name	Detailed instruction	Default value	Modify
		3: Static autotuning 2 (partial autotuning)		
P00.16	AVR function selection	0: Invalid 1: Valid the whole time	1	○
P00.17	Inverter type	0: G type 1: P type	0	◎
P00.18	Function parameter restoration	0: No operation 1: Restore to default value 2: Clear fault history Note: During restoring to default value, the motor parameter in P02 group stays in current value and P18.04, P18.28, P18.29, P18.32, P18.33 and P18.38 also stay in current value.	0	◎
P01.01	Starting frequency of direct start-up	0.00–50.00Hz	0.50Hz	◎
P01.08	Stop mode selection	0: Decelerate to stop 1: Coast to stop	0	○
P01.15	Stop speed	0.00–100.00Hz	0.50Hz	◎
P01.16	Detection mode of stop speed	0: Detect by the setting value of the speed (determine the ramps frequency) 1: Detect by the feedback value of the speed (valid only for vector control)	1	◎
P01.17	Detection time of feedback speed	0.00–100.00 s (valid only when P01.16=1)	0.50s	◎
P02.00	Motor 1 type	0: AM 1: SM	0	◎
P02.01	Rated power of AM 1	0.1–3000.0kW	Depend on model	◎
P02.02	Rated frequency of AM 1	0.01Hz–P00.03 (Max. output frequency)	50.00Hz	◎
P02.03	Rated rotation speed of AM 1	1–36000rpm	Depend on model	◎
P02.04	Rated voltage of AM 1	0–1200V	Depend on model	◎
P02.05	Rated current of AM 1	0.8–6000.0A	Depend on	◎

Function code	Name	Detailed instruction	Default value	Modify
			model	
P02.06	Stator resistance of AM 1	0.001–65.535Ω	Depend on model	<input type="radio"/>
P02.07	Rotor resistance of AM 1	0.001–65.535Ω	Depend on model	<input type="radio"/>
P02.08	Leakage inductance of AM 1	0.1–6553.5mH	Depend on model	<input type="radio"/>
P02.09	Mutual inductance of AM 1	0.1–6553.5mH	Depend on model	<input type="radio"/>
P02.10	No-load current of AM 1	0.1–6553.5A	Depend on model	<input type="radio"/>
P02.11	Core magnetic saturation coefficient 1 of AM 1	0.0–100.0%	80.0%	<input checked="" type="radio"/>
P02.12	Core magnetic saturation coefficient 2 of AM 1	0.0–100.0%	68.0%	<input checked="" type="radio"/>
P02.13	Core magnetic saturation coefficient 3 of AM 1	0.0–100.0%	57.0%	<input checked="" type="radio"/>
P02.14	Core magnetic saturation coefficient 4 of AM 1	0.0–100.0%	40.0%	<input checked="" type="radio"/>
P02.15	Rated power of SM 1	0.1–3000.0kW	Depend on model	<input checked="" type="radio"/>
P02.16	Rated frequency of SM 1	0.01Hz–P00.03 (Max. output frequency)	50.00Hz	<input checked="" type="radio"/>
P02.17	Number of pole pairs of SM 1	1–50	2	<input checked="" type="radio"/>
P02.18	Rated voltage of SM 1	0–1200V	Depend on model	<input checked="" type="radio"/>

Function code	Name	Detailed instruction	Default value	Modify
P02.19	Rated current of SM 1	0.8–6000.0A	Depend on model	☉
P02.20	Stator resistance of SM 1	0.001–65.535Ω	Depend on model	○
P02.21	D-axis inductance of SM 1	0.01–655.35mH	Depend on model	○
P02.22	Q-axis inductance of SM 1	0.01–655.35mH	Depend on model	○
P02.23	Counter electromotive force constant of SM 1	0–10000	350	○
P02.26	Overload protection selection of motor 1	0: No protection 1: Regular motor (with low speed compensation) 2: Inverter motor (w/o low speed compensation)	2	☉
P02.27	Overload protection coefficient of motor 1	Motor overload multiple $M = I_{out} / (I_n * K)$ I_n is rated motor current, I_{out} is output current of the inverter, and K is motor overload protection coefficient. The smaller the value of K , the larger the value of M and the easier the protection. When $M=116\%$, protect when motor overload lasts for 1 hour; when $M=150\%$, protect when motor overload lasts for 12 minutes; when $M=180\%$, protect when motor overload lasts for 5 minutes; when $M=200\%$, protect when motor overload lasts for 60 seconds; when $M \geq 400\%$, protect immediately.	100.0%	○

Function code	Name	Detailed instruction	Default value	Modify
		<p>Setting range: 20.0%–120.0%</p>		
P02.28	Power correction coefficient of motor 1	0.00–3.00	1.00	<input type="radio"/>
P02.29	Parameter display selection of motor 1	0: Display based on motor type 1: Display all	0	<input type="radio"/>
P03.00	Speed loop proportional gain 1	0–200.0	20.0	<input type="radio"/>
P03.01	Speed loop integral time 1	0.000–10.000s	0.200s	<input type="radio"/>
P03.02	Switching low point frequency	0.00Hz–P03.05	5.00Hz	<input type="radio"/>
P03.03	Speed loop proportional gain 2	0–200.0	20.0	<input type="radio"/>
P03.04	Speed loop integral time 2	0.000–10.000s	0.200s	<input type="radio"/>
P03.05	Switching high point frequency	P03.02–P00.03 (Max. output frequency)	10.00Hz	<input type="radio"/>
P03.06	Speed loop output filter	0–8 (corresponds to 0–2^8/10ms)	0	<input type="radio"/>
P03.07	Vector control electric motion slip compensation coefficient	50%–200%	100%	<input type="radio"/>
P03.08	Vector control power generation slip compensation coefficient	50%–200%	100%	<input type="radio"/>
P03.09	Current loop	0–65535	Depend	<input type="radio"/>

Function code	Name	Detailed instruction	Default value	Modify																					
	proportional coefficient P	The default value of P03.09 and P03.10 is different in differing power ranges. Set power ranges by touch screen and they will be set to the following empirical parameters after autotuning. <table border="1" style="margin-left: 20px;"> <thead> <tr> <th>Empirical value of P03.09 (for reference only)</th> <th>Empirical value of P03.10 (for reference only)</th> <th>Motor power</th> </tr> </thead> <tbody> <tr> <td>2000</td> <td>1000</td> <td>15kW</td> </tr> <tr> <td>2000</td> <td>1000</td> <td>18.5kW</td> </tr> <tr> <td>2000</td> <td>1000</td> <td>22kW</td> </tr> <tr> <td>2500</td> <td>1500</td> <td>37kW</td> </tr> <tr> <td>3000</td> <td>1500</td> <td>55kW</td> </tr> <tr> <td>3000</td> <td>1500</td> <td>75kW</td> </tr> </tbody> </table>	Empirical value of P03.09 (for reference only)	Empirical value of P03.10 (for reference only)	Motor power	2000	1000	15kW	2000	1000	18.5kW	2000	1000	22kW	2500	1500	37kW	3000	1500	55kW	3000	1500	75kW	on model	
Empirical value of P03.09 (for reference only)	Empirical value of P03.10 (for reference only)	Motor power																							
2000	1000	15kW																							
2000	1000	18.5kW																							
2000	1000	22kW																							
2500	1500	37kW																							
3000	1500	55kW																							
3000	1500	75kW																							
P03.10	Current loop integral coefficient I		Depend on model	<input type="radio"/>																					
P03.20	Keypad setting of electric motion torque upper limit	0.0–300.0% (rated motor current)	180.0%	<input type="radio"/>																					
P03.21	Keypad setting of braking torque upper limit	0.0–300.0% (rated motor current)	180.0%	<input type="radio"/>																					
P03.22	Weak magnetic coefficient of constant power area	0.1–2.0	0.3	<input type="radio"/>																					
P03.23	Min. weak magnetic point of constant power area	10%–100%	20%	<input type="radio"/>																					
P03.24	Max. voltage limit	0.0–120.0%	100.0%	<input type="radio"/>																					
P03.25	Pre-excitation time	0.000–10.000s	0.300s	<input type="radio"/>																					
P03.26	Weak magnetic proportional gain	0–8000	300	<input type="radio"/>																					
P03.27	Speed display of vector control	0: Display based on actual value 1: Display based on the set value	0	<input type="radio"/>																					
P03.28	Injected current at start	0.0–100.0%; setting range: 0–100.0	60.0%	<input type="radio"/>																					
P03.29	Inductance coefficient	0.2–4.0; setting range: 0.2–4.0	1.0	<input type="radio"/>																					
P04.00	V/F curve setting of	0: Straight V/F curve	0	<input checked="" type="radio"/>																					

Function code	Name	Detailed instruction	Default value	Modify
	motor 1	1: Multi-point V/F curve 2: 1.3 power of torque reduction V/F curve 3: 1.7 power of torque reduction V/F curve 4: 2.0 power of torque reduction V/F curve 5: Reserved		
P04.01	Torque elevator of motor 1	0.0%: (automatic) 0.1%–10.0%	0.0%	<input type="radio"/>
P04.02	Torque elevation cut-off of motor 1	0.0%–50.0% (relative to rated frequency of motor 1)	20.0%	<input type="radio"/>
P04.03	V/F frequency point 1 of motor 1	0.00Hz–P04.05	0.00Hz	<input type="radio"/>
P04.04	V/F voltage point 1 of motor 1	0.0%–110.0% (rated voltage of motor 1)	00.0%	<input type="radio"/>
P04.05	V/F frequency point 2 of motor 1	P04.03– P04.07	00.00Hz	<input type="radio"/>
P04.06	V/F voltage point 2 of motor 1	0.0%–110.0% (rated voltage of motor 1)	00.0%	<input type="radio"/>
P04.07	V/F frequency point 3 of motor 1	P04.05–P02.02 (rated frequency of motor 1) /P04.05–P02.16 (rated frequency of motor 1)	00.00Hz	<input type="radio"/>
P04.08	V/F voltage point 3 of motor 1	0.0%–110.0% (rated voltage of motor 1)	00.0%	<input type="radio"/>
P04.09	V/F slip compensation gain of motor 1	0.0–200.0%	100.0%	<input type="radio"/>
P04.10	Low frequency restraining vibration factor of motor 1	0–100	10	<input type="radio"/>
P04.11	High frequency restraining vibration factor of motor 1	0–100	10	<input type="radio"/>
P04.12	Restraining vibration cut-off point of motor 1	0.00Hz–P00.03 (Max. output frequency)	30.00Hz	<input type="radio"/>
P04.26	Energy-saving running selection	0: No action 1: Automatic energy-saving running	0	<input checked="" type="radio"/>
P04.33	Weak magnetic coefficient of constant power area	1.00–1.30	1.00	<input type="radio"/>
P04.34	Reactive closed-loop proportional coefficient	0–3000	100	<input type="radio"/>

Function code	Name	Detailed instruction	Default value	Modify
P04.35	Reactive closed-loop integral coefficient	0-3000	20	<input type="radio"/>
P05.00	Reserved	Reserved	0	<input checked="" type="radio"/>
P05.01	S1 terminal function selection	0: No function 1: Forward rotation running 2: Reverse rotation running 3: Three-wire running control 4: Forward rotation jogging 5: Reverse rotation jogging 6: Coast to stop 7: Fault reset 8: Running pause 9: External fault input 10-24: Reserved 25: PID control pause 26-39: Reserved 40: Clear power consumption 41: Maintain power consumption 42: Air filter block signal 43: Oil filter block signal 44: Separator block signal 45: Splitter block signal 46: External fault 1 47: External fault 2 48: Fan running control signal 49: Solenoid valve control signal 50: Cooling fan control signal of main motor 51-63: Reserved	0	<input checked="" type="radio"/>
P05.02	S2 terminal function selection		0	<input checked="" type="radio"/>
P05.03	S3 terminal function selection		0	<input checked="" type="radio"/>
P05.04	S4 terminal function selection		0	<input checked="" type="radio"/>
P05.05	S5 terminal function selection		0	<input checked="" type="radio"/>
P05.06	Reserved			<input checked="" type="radio"/>
P05.10	Input terminal polarity	This function code is used to set the polarity of	0x000	<input type="radio"/>

Function code	Name	Detailed instruction	Default value	Modify																				
	selection	input terminals. When the bit is set to 0, input terminal is positive polarity; When the bit is set to 1, input terminal is negative polarity <table border="1" style="margin-left: auto; margin-right: auto;"> <tr> <td></td> <td>BIT8</td> <td>BIT7</td> <td>BIT6</td> <td>BIT5</td> </tr> <tr> <td></td> <td>Reserved</td> <td>Reserved</td> <td>Reserved</td> <td>Reserved</td> </tr> <tr> <td>BIT4</td> <td>BIT3</td> <td>BIT2</td> <td>BIT1</td> <td>BIT0</td> </tr> <tr> <td>S5</td> <td>S4</td> <td>S3</td> <td>S2</td> <td>S1</td> </tr> </table> Setting range: 0x000–0x1FF		BIT8	BIT7	BIT6	BIT5		Reserved	Reserved	Reserved	Reserved	BIT4	BIT3	BIT2	BIT1	BIT0	S5	S4	S3	S2	S1		
	BIT8	BIT7	BIT6	BIT5																				
	Reserved	Reserved	Reserved	Reserved																				
BIT4	BIT3	BIT2	BIT1	BIT0																				
S5	S4	S3	S2	S1																				
P05.11	Digital filter time	0.000–1.000s	0.200s	○																				
P05.14	Close delay time of S1 terminal	0.000–50.000s	0.000s	○																				
P05.15	Turn-off delay time of S1 terminal	0.000–50.000s	0.000s	○																				
P05.16	Close delay time of S2 terminal	0.000–50.000s	0.000s	○																				
P05.17	Turn-off delay time of S2 terminal	0.000–50.000s	0.000s	○																				
P05.18	Close delay time of S3 terminal	0.000–50.000s	0.000s	○																				
P05.19	Turn-off delay time of S3 terminal	0.000–50.000s	0.000s	○																				
P05.20	Close delay time of S4 terminal	0.000–50.000s	0.000s	○																				
P05.21	Turn-off delay time of S4 terminal	0.000–50.000s	0.000s	○																				
P05.22	Close delay time of S5 terminal	0.000–50.000s	0.000s	○																				
P05.23	Turn-off delay time of S5 terminal	0.000–50.000s	0.000s	○																				
P05.32	Lower limit value of P1	0.00V–P05.34	2.00V	○																				
P05.33	Corresponding setting of P1 lower limit	-100.0%–100.0%	0.0%	○																				
P05.34	Upper limit value of P1	P05.32–10.00V	10.00V	○																				
P05.35	Corresponding setting of P1 upper limit	-100.0%–100.0%	100.0%	○																				

Function code	Name	Detailed instruction	Default value	Modify
P05.36	Input filter time of P1	0.000s–10.000s	0.200s	<input type="radio"/>
P05.37	Lower limit value of PT1	0.00V–P05.39	0.00V	<input type="radio"/>
P05.38	Corresponding setting of PT1 lower limit	-100.0%–100.0%	-12.5%	<input type="radio"/>
P05.39	Upper limit value of PT1	P05.37–10.00V	10.00V	<input type="radio"/>
P05.40	Corresponding setting of PT1 upper limit	-100.0%–100.0%	93.8%	<input type="radio"/>
P05.41	Input filter time of PT1	0.000s–10.000s	0.300s	<input type="radio"/>
P05.42	Lower limit value of P2	0.00V–P05.44	2.00V	<input type="radio"/>
P05.43	Corresponding setting of P2 lower limit	-100.0%–100.0%	0.0%	<input type="radio"/>
P05.44	Upper limit value of P2	P05.42–10.00V	10.00V	<input type="radio"/>
P05.45	Corresponding setting of P2 upper limit	-100.0%–100.0%	100.0%	<input type="radio"/>
P05.46	Input filter time of P2	0.000s–10.000s	0.200s	<input type="radio"/>
P05.47	Lower limit value of PT2	0.00V–P05.49	0.00V	<input type="radio"/>
P05.48	Corresponding setting of PT2 lower limit	-100.0%–100.0%	-12.5%	<input type="radio"/>
P05.49	Upper limit value of PT2	P05.47–10.00V	10.00V	<input type="radio"/>
P05.50	Corresponding setting of PT2 upper limit	-100.0%–100.0%	93.8%	<input type="radio"/>
P05.51	Input filter time of PT2	0.000s–10.000s	0.300s	<input type="radio"/>
P06.01	Y output selection	0: In valid 1: Running 2: Forward rotation running 3: Reserved rotation running 4: Jogging running 5: Inverter fault 6–11: Reserved 12: Ready to run 13: Pre-exciting 14–19: Reserved 20: External fault is valid 21–22: Reserved	5	<input type="radio"/>

Function code	Name	Detailed instruction	Default value	Modify								
		23: MODBUS communication virtual terminal output 24–26: Reserved 27: Start/stop control of auxiliary motor (air compressor-specific) 28: Solenoid valve control output (air compressor-specific) 29: Cooling fan control of main motor (air compressor-specific) 30: Reserved										
P06.02	Reserved		0	○								
P06.03	TAC1 output selection		0	○								
P06.04	TAC2 output selection		0	○								
P06.05	Polarity selection of output terminal	This function code is used to set the polarity of output terminals. When the bit is set to 0, output terminal is positive polarity; When the bit is set to 1, output terminal is negative polarity <table border="1" style="margin-left: auto; margin-right: auto;"> <tr> <td>BIT3</td> <td>BIT2</td> <td>BIT1</td> <td>BIT0</td> </tr> <tr> <td>TAC2</td> <td>TAC1</td> <td>Reserved</td> <td>Y</td> </tr> </table> Setting range: 0–0xF	BIT3	BIT2	BIT1	BIT0	TAC2	TAC1	Reserved	Y	0	○
BIT3	BIT2	BIT1	BIT0									
TAC2	TAC1	Reserved	Y									
P06.06	Delay time of Y connection	0.000–50.000s	0.000s	○								
P06.07	Delay time of Y disconnection	0.000–50.000s	0.000s	○								
P06.08	Reserved	0.000–50.000s	0.000s	○								
P06.09	Reserved	0.000–50.000s	0.000s	○								
P06.10	Delay time of TAC1 connection	0.000–50.000s	0.000s	○								
P06.11	Delay time of TAC1 disconnection	0.000–50.000s	0.000s	○								
P06.12	Delay time of TAC2 connection	0.000–50.000s	0.000s	○								
P06.13	Delay time of TAC2 disconnection	0.000–50.000s	0.000s	○								
P07.00	User password	0–65535	0	○								
P07.01	Copy of function	0: No operation	0x00	◎								

Function code	Name	Detailed instruction	Default value	Modify
	parameters	1: Upload function parameters to the keypad 2: Download keypad function parameters to the machine (including motor parameters) 3: Download keypad function parameters to the machine (excluding P02 and P12 parameter groups) 4: Download keypad function parameters to the machine (including P02 and P12 parameter groups only) Note: After the parameter is set to 1, 2, 3 or 4, and the operation is executed, the parameter is automatically restored to 0. The parameters uploaded or downloaded do not include those of the P29 group (factory function parameters). Tens place: Parameter group setting 0-4: Group 1-group 5 Setting range: 0x00-0x44		
P07.11	Temperature of rectifier module	0-100.0°C		●
P07.12	Temperature of inverter module	0-100.0°C		●
P07.13	Software version of control board	1.00-655.35		●
P07.14	Accumulated running time of the machine	0-65535h		●
P07.15	High bit of inverter power consumption	0-65535 kWh (*1000)		●
P07.16	Low bit of inverter power consumption	0.0-999.9 kWh		●
P07.17	Inverter model	0: G type 1: P type		●
P07.18	Rated inverter power	0.4-3000.0kW		●
P07.19	Rated inverter voltage	50-1200V		●
P07.20	Rated inverter current	0.1-6000.0A		●
P07.21	Factory bar code 1	0x0000-0xFFFF		●
P07.22	Factory bar code 2	0x0000-0xFFFF		●
P07.23	Factory bar code 3	0x0000-0xFFFF		●
P07.24	Factory bar code 4	0x0000-0xFFFF		●

Function code	Name	Detailed instruction	Default value	Modify
P07.25	Factory bar code 5	0x0000–0xFFFF		●
P07.26	Factory bar code 6	0x0000–0xFFFF		●
P07.27	Current fault type	0: No fault 1: Inverter unit U phase protection (OUt1) 2: Inverter unit V phase protection (OUt1) 3: Inverter unit W phase protection (OUt1) 4: Overcurrent at acceleration (OC1) 5: Overcurrent at deceleration (OC2) 6: Overcurrent at constant speed (OC3) 7: Overvoltage at acceleration (OV1) 8: Overvoltage at deceleration (OV2) 9: Overvoltage at constant speed (OV3) 10: Bus undervoltage fault (UV) 11: Motor overload (OL1) 12: Inverter overload (OL2) 13: Phase loss on input side (SPI) 14: Phase loss on output side (SPO) 15: Overheat of rectifier module (OH1) 16: Overheat fault of inverter module (OH2) 17: External fault (EF) 18: 485 communication fault (CE) 19: Current detection fault (ItE) 20: Motor autotuning fault (tE) 21: EEPROM operation fault (EEP) 22: PID feedback disconnection fault (PIDE) 23: Reserved 24: Running time up (END) 25: Electronic overload (OL3) 26: Panel communication error (PCE) 27: Parameter uploading error (UPE) 28: Parameter downloading error (DNE) 29–31: Reserved 32: Grounding short circuit fault 1 (ETH1) 33: Grounding short circuit fault 2 (ETH2) 34: Speed deviation fault (dEu) 35: Maladjustment fault (STo) 36: Underload fault (LL) 37: Auxiliary fan fault (E_FAN)		●

Function code	Name	Detailed instruction	Default value	Modify
		38: Phase sequence fault (PSF)		
P07.28	Type of last one fault			●
P07.29	Type of the last two faults			●
P07.30	Type of the last three faults			●
P07.31	Type of the last four faults			●
P07.32	Type of the last five faults			●
P08.15	Bus voltage pre-protection function	0–1	0	○
P08.16	Low voltage protection threshold	0.0V–2000.0V	300.0V	○
P08.17	Overvoltage pre-protection threshold	0.0V–2000.0V	780.0V	○
P08.18	Delay time of automatic start-up	0.0–6000.0s	60.0s	○
P08.19	Low voltage frequency-limit running time	0.0–6000.0s	60.0s	○
P08.26	Counting mode of maintenance time	0–1 0: Counting during motor running 1: Counting during motor running and sleeping	0	○
P09.00	PID reference source selection	0: Keypad digital reference (P09.01) 1: Analog P1-reference 2: Reserved 3: Analog P2-setting 4: Reserved 5: Multi-step reference 6: MODBUS communication setting 7–9: Reserved 10: Pressure setting for air compressor-specific function	0	○
P09.01	Keypad pre-set PID reference	-100.0%–100.0%	0.0%	○
P09.02	PID feedback source	0: Analog P1-feedback	0	○

Function code	Name	Detailed instruction	Default value	Modify
	selection	1: Reserved 2: Analog P2-feedback 3: Reserved 4: MODBUS communication feedback 5-7: Reserved 8: Pressure feedback for air compressor-specific function		
P09.03	PID output characteristic selection	0: PID output is positive characteristic: namely, the feedback signal is larger than PID reference, which requires the inverter output frequency to decrease to enable PID to reach balance, such as tension PID control of winding. 1: PID output is negative characteristic: namely, the feedback signal is less than PID reference, which requires the inverter output frequency to increase to enable PID to reach balance, such as tension PID control of unwinding.	0	<input type="radio"/>
P09.04	Proportional gain (Kp)	It determines the adjustment intensity of the whole PID regulator, the larger the value of P, the stronger the adjustment intensity. If this parameter is 100, it means when the deviation between PID feedback quantity and reference quantity is 100%, the adjustment amplitude of proportional controller (ignoring integral and differential effect) against output frequency command is the maximum output frequency (P00.03). Setting range: 0.00-100.00	10.00	<input type="radio"/>
P09.05	Integral time (Ti)	It determines the speed of integral adjustment made by PID regulator against the deviation of PID feedback quantity and reference quantity. When the deviation between PID feedback quantity and reference quantity is 100%, the adjustment quantity of integral regulator (ignoring integral and differential effect), after undergoing continuous adjustment during this time period, can reach the maximum output frequency (P00.03)	2.00s	<input type="radio"/>

Function code	Name	Detailed instruction	Default value	Modify
		The shorter the integral time, the stronger the adjustment intensity. Setting range: 0.00–10.00s		
P09.06	Differential time (Td)	It determines the intensity of the adjustment made by PID regulator against the change rate of deviation between PID feedback quantity and reference quantity. If feedback quantity changes 100% during this time period, the adjustment quantity of differential regulator (ignoring integral and differential effect) is the maximum output frequency (P00.03) The longer the differential time, the stronger the adjustment intensity. Setting range: 0.00–10.00s	1.00s	<input type="radio"/>
P09.07	Sampling cycle (T)	It means the sampling cycle of feedback quantity. The regulator calculates once during each sampling cycle. The larger the sampling cycle, the slower the response. Setting range: 0.001–10.000s	0.100s	<input type="radio"/>
P09.08	Limit of PID control deviation	It is the max. allowed deviation quantity relative to close-loop reference value of PID system feedback value. Within this limit, PID regulator stops adjustment. Set this function code properly to adjust the precision and stability of PID system. Setting range: 0.0–100.0%	0.1%	<input type="radio"/>
P09.09	Upper limit value of PID output	P09.10–100.0% (max. frequency)	100.0%	<input type="radio"/>
P09.10	Lower limit value of PID output	-100.0%–P09.09 (max. frequency)	0.0%	<input type="radio"/>
P09.11	Detection value of feedback disconnection	0.0–100.0%	0.0%	<input type="radio"/>
P09.12	Detection time of feedback disconnection	0.0–3600.0s	1.0s	<input type="radio"/>
P09.13	PID adjustment selection	0x00–0x11 LED ones:	0x01	<input type="radio"/>

Function code	Name	Detailed instruction	Default value	Modify
		0: Continuing integral adjustment after the frequency reaches upper/lower limit 1: Stop integral adjustment after the frequency reaches upper/lower limit LED hundreds: 0: consistent with the set direction 1: can be contrary to the set direction		
P09.14	Differential filter times	0–60	2	<input type="radio"/>
P11.00	Phase-loss protection	0x0000–0x1111 LED ones: 0: Input phase loss software protection is prohibited 1: Input phase loss software protection is allowed Note: LED ones detects input phase loss by phase sequence detection circuit LED tens: 0: Output phase loss protection is prohibited 1: Output phase loss protection is allowed LED hundreds: 0: Input phase loss hardware protection is prohibited 1: Input phase loss hardware protection is allowed Note: LED hundreds detects input phase loss by hardware detection circuit LED thousands: 0: Phase sequence protection is prohibited 1: Phase sequence protection is allowed	0x0110	<input type="radio"/>
P11.01	Frequency-decreasing at momentary power drop	0: Prohibited 1: Allowed	0	<input type="radio"/>
P11.02	Frequency-decreasing rate at momentary power drop	0.00Hz–P00.03/s (Max. output frequency)	10.00Hz/s	<input type="radio"/>
P11.03	Overvoltage stall protection	0: Prohibited 1: Allowed	1	<input type="radio"/>
P11.04	Overvoltage stall protection voltage	120–150% (standard bus voltage) (380V)	140%	<input type="radio"/>

Function code	Name	Detailed instruction	Default value	Modify
P11.05	Current-limit selection	0x00–0x11 Ones: Current-limit action 0: Current-limit action is invalid 1: Current-limit action is valid all the time Tens: Hardware current-limit overload alarm 0: Hardware current-limit overload alarm is valid 1: Hardware current-limit overload alarm is invalid	01	☉
P11.06	Automatic current-limit level	50.0–200.0%	160.0%	☉
P11.07	Frequency-decreasing rate during current limiting	0.00–50.00Hz/s	10.00Hz/s	☉
P11.13	Fault output terminal action during fault	0x00–0x11 LED ones: 0: Act during undervoltage fault 1: No action during undervoltage fault LED tens: 0: Act during automatic reset period 1: No action during automatic reset period	0x00	○
P11.14	Detection value of speed deviation	0.0–50.0%	10.0%	○
P11.15	Detection time of speed deviation	0.0–10.0s (no speed deviation protection during 0.0)	0.5s	○
P11.16	Automatic frequency-decreasing at voltage drop	0: Invalid 1: Valid	1	○
P13.00	Reduction coefficient of pull-in current	0.0–100.0%	50.0%	○
P13.01	Detection mode of initial magnetic pole	0: No detection 1: High frequency overlay (reserved) 2: Pulse overlay (reserved)	0	☉
P13.02	Pull-in current 1	0.0%–100.0% rated motor current	20.0%	○
P13.03	Pull-in current 2	0.0%–100.0% rated motor current	10.0%	○
P13.04	Switching frequency of pull-in current	0.00Hz–P00.03 (Max. output frequency)	30.00Hz	○
P13.05	High frequency overlay frequency	200Hz–1000Hz	500Hz	☉

Function code	Name	Detailed instruction	Default value	Modify
	(reserved)			
P13.06	High frequency overlay voltage	0.0–300.0% rated motor voltage	40.0%	☉
P13.08	Control parameter 1	0–FFFF	0x120	○
P13.09	Control parameter 2	0–300.00	5.00	○
P13.11	Detection time of maladjustment	Adjust the responsiveness of anti-maladjustment function. When load inertia is large, increase this value properly, but the responsiveness may become slow consequently. Setting range: 0.0–10.0s	0.5s	○
P13.12	High frequency compensation coefficient	This parameter is valid when the rotation speed of the motor exceeds the rated value. If motor oscillation occurred, adjust this parameter properly. Setting range: 0.0–100.0%	50.0%	○
P14.00	Local communication address	1–247, 0 is the broadcasting add.	2	○
P14.01	Communication baud rate setting	0: 1200BPS 1: 2400BPS 2: 4800BPS 3: 9600BPS 4: 19200BPS 5 : 38400BPS	4	○
P14.02	Data bit check setting	0: No check (N, 8, 1) for RTU 1: Even parity check (E, 8, 1) for RTU 2: Odd parity check (O, 8, 1) for RTU 3: No check (N, 8, 2) for RTU 4: Even parity check (E, 8, 2) for RTU 5: Odd parity check (O, 8, 2) for RTU	1	○
P14.03	Communication response delay	0–200ms	5	○
P14.04	Communication time-out fault time	0.0 (invalid), 0.1–60.0s	0.0s	○
P14.05	Transmission error processing	0: Alarm and coast to stop 1: Do not alarm and continue running 2: Do not alarm and stop in stop mode (only under communication control mode) 3: Do not alarm and stop in stop mode (under all	0	○

Function code	Name	Detailed instruction	Default value	Modify
		control modes)		
P14.06	Communication processing action	0x00–0x11 LED ones: Writing operation acts 0: There is response for writing operation 1: No response for writing operation LED tens: Communication encryption processing 0: Communication encryption is invalid 1: Communication encryption is valid	0x00	○
P14.07	Communication address of auxiliary fan	1–247, 0 is broadcasting add.	1	○
P17.00	Setting frequency	0.00Hz–P00.03	0.00Hz	●
P17.01	Output frequency	0.00Hz–P00.03	0.00Hz	●
P17.02	Ramps reference frequency	0.00Hz–P00.03	0.00Hz	●
P17.03	Output voltage	0–1200V	0V	●
P17.04	Output current	0.0–3000.0A	0.0A	●
P17.05	Motor rotation speed	0–65535RPM	0 RPM	●
P17.06	Torque current	-3000.0–3000.0A	0.0A	●
P17.07	Excitation current	-3000.0–3000.0A	0.0A	●
P17.08	Motor power	-300.0%–300.0% (relative to rated motor power)	0.0%	●
P17.09	Output torque	-250.0–250.0%	0.0%	●
P17.10	Estimated motor frequency	0.00– P00.03	0.00Hz	●
P17.11	DC bus voltage	0.0–2000.0V	0V	●
P17.12	Digital input terminal state	0000–00FF	0	●
P17.13	Digital output terminal state	0000–000F	0	●
P17.16	Master fault code	0–38 (see details at P07.27–P07.32)	0	●
P17.17	Fan fault code	0–38 (see details at P07.27–P07.32)	0	●
P17.19	P1-input voltage	Display analog input voltage value of P1-channel. 2.00V–10.00V corresponds to 4–50mA. P05.32-P05.34 corresponds to pressure 0.0–P18.04. When P1-input voltage is detected to be above 9.8V or below 1V, it is deemed as pressure signal fault Range: 0.00–10.00V	0.00V	●

Function code	Name	Detailed instruction	Default value	Modify
P17.20	PT1 input voltage	Display the analog input voltage value of PT1 channel. Connect PT100 thermal resistor temperature sensor in air compressor mode, and different resistance value will be generated under different temperature. Different resistance value corresponds to different input voltage. Therefore, the input voltage value can correspond to the corresponding detection temperature. The input voltage P18.28-P18.29 corresponds to -20℃ -150℃. Range: 0.00-10.00V	0.00V	●
P17.21	P2-input voltage	Display the analog input voltage value of P2-channel. 2.00V-10.00V corresponds to 4-20mA. P05.42-P05.44 corresponds to 0.0-P18.38. When P2-input voltage is detected to be above 9.8V or below 1V, it is deemed as pressure signal fault. Range: 0.00-10.00V	0.00V	●
P17.22	PT2 input voltage	Display the analog input voltage value of PT2 channel. Connect PT100 thermal resistor temperature sensor in air compressor mode, and different resistance value will be generated under different temperature. Different resistance value corresponds to different input voltage. Therefore, the input voltage value can correspond to the corresponding detection temperature. The input voltage P18.32-P18.33 corresponds to -20℃ -150℃. Range: 0.00-10.00V	0.00V	●
P17.23	PID reference value	Display the set value of exhaust pressure signal. 100.0% corresponds to the upper limit value of exhaust pressure sensor P18.04 (If P18.37=1, 100% corresponds to P18.38) Range: -100.0-100.0%	0.0%	●
P17.24	PID feedback value	Display detection value of exhaust pressure signal Range: -100.0-100.0%	0.0%	●
P17.25	Motor power factor	-1.00-1.00	0.0	●

Function code	Name	Detailed instruction	Default value	Modify
P17.26	Running time of this time	0-65535m	0m	●
P17.28	ASR controller output	-300.0%-300.0% (rated motor current)	0.0%	●
P17.29	Magnetic pole angle of SM	0.0-360.0	0.0	●
P17.30	Phase compensation quantity of SM	-180.0-180.0	0.0	●
P17.36	Output torque	-3000.0Nm-3000.0Nm	0.0Nm	●
P17.38	PID output value	Display PID control adjustment output value of exhaust pressure signal. 100.0% corresponds to maximum output frequency P00.03. Setting range: -100.00-100.00%	0.00%	●
P18.00	Air compressor control mode	0: Invalid 1: Air compressor control mode Note: When P18.00=1, P19 group air compressor state check group is valid	0	◎
P18.01	Sleep function selection	0: Invalid 1: Valid Note: When sleep function is valid and unloading condition is met, the inverter running frequency decelerates to P18.12, after that, if the duration time P18.13 of exhaust pressure is larger than loading pressure P18.06, the inverter will decelerate to stop speed P01.15 and then coast to stop to enter sleep stage. If the exhaust pressure is lower than loading pressure within P18.13, the inverter will carry out loading operation again and pressure PID will regulate accordingly.	1	◎
P18.02	Loading/unloading mode	0: Automatic 1: Manual If set to manual state, loading/unloading requires manual operation after air compressor starts; if set to automatic, load/unloading will be conducted automatically according to the pressure after air compressor starts.	0	○
P18.03	Temperature sensor channel	0: head temperature PT1, auxiliary temperature PT2	0	◎

Function code	Name	Detailed instruction	Default value	Modify
		1: head temperature PT2, auxiliary temperature PT1		
P18.04	Upper limit of pressure sensor P1	0.00–20.00 Mpa It is related to actual range of pressure sensor. The voltage corresponds to P18.04 is P05.34 Note: This value stays in current set value during restoring to factory value.	1.60Mpa	☉
P18.05	Unloading pressure	In automatic loading/unloading mode, when air compressor control is valid and air supply of the compressor becomes normal after it starts, if exhaust pressure is detected to be above P18.05, automatic unloading will be applied. If sleep function is valid (P18.01=1), the inverter enters sleep state; when exhaust pressure is detected to be below P18.06, automatic loading will be applied. P18.07 is used to set the air supply pressure when air compressor operation is stable. During loading operation, the rotation speed of the master is controlled by pressure PID. The system keeps exhaust pressure constant by adjusting the rotation speed of the master. Refer to section 5.2 for process logic of pressure control. Setting range: 0.00–P18.04	0.80Mpa	○
P18.06	Loading pressure		0.60Mpa	○
P18.07	Setting pressure		0.70Mpa	○
P18.08	Starting temperature of the fan	When the head temperature exceeds P18.08, the fan starts. When the head temperature is below P18.09, the fan stops. P18.10 is used to set the target head temperature during stable running of the air compressor. The rotation speed of fan is controlled by constant temperature PID (P18.42=0). Constant temperature control is realized by PID calculation based on P18.10 and	75℃	○

Function code	Name	Detailed instruction	Default value	Modify
		the head temperature. Setting range:-20–150		
P18.09	Stop temperature of the fan		65℃	○
P18.10	Setting temperature		75℃	○
P18.11	Lower limit frequency of loading operation	P18.12–P00.04 (upper limit of running frequency) It is the min. working frequency allowed to be output when the pressure is above the set working pressure but below the unloading pressure during adjustment.	40.00Hz	○
P18.12	No-load operation frequency	P01.15–P18.11 (lower limit frequency of loading operation) It is the working frequency allowed to be output during no-load of air compressor.	38.00 Hz	○
P18.13	Delay time of no load	When sleep function is valid, the inverter, after unloading, runs at the no-load running frequency until passing the time set by P18.13, then it enters sleep state. Sleep function can be enabled when the gas consumption is relatively small. If sleep function is valid, decrease P18.13 to make the device enter sleep state at faster speed. Setting range: 0–3600s	300s	○
P18.14	Delay time of stop	After stop command is valid, the inverter runs at no-load running frequency until passing the time set by P18.14 and then it stops. Setting range:0–3600s	0s	○
P18.15	Delay time of loading	Loading operation can only be available after the master runs at no-load frequency by the time set by P18.15. Setting range: 0–3600s	10s	○
P18.16	Delay time of restart	After system stops, wait for the time set by P18.16 before determining whether to start again. Setting range: 0–3600s	30s	○
P18.17	Pre-alarm pressure	When the current exhaust pressure is detected to be above P18.17, the system releases pressure	0.90Mpa	○

Function code	Name	Detailed instruction	Default value	Modify
		pre-alarm by changing BIT8 of P19.13 to 1. When the current exhaust pressure is detected to be above P18.18, the system releases pressure alarm by changing BIT10 of P19.13 to 1 and emergency stop will be applied. Setting range: 0.00–P18.04		
P18.18	Alarm pressure		1.00Mpa	<input type="radio"/>
P18.19	Pre-alarm temperature	When head temperature is detected to be above P18.19, system releases temperature pre-alarm by changing BIT9 of P19.13 to 1. When head temperature is detected to be above P18.20, system releases temperature alarm by changing BIT11 of P19.13 to 1 and emergency stop will be applied. When head temperature is detected to be below P18.21, system releases low temperature pre-alarm by changing BIT14 of P19.13 to 1 and the air compressor will be prohibited from starting. Setting range: -20–150	105℃	<input type="radio"/>
P18.20	Alarm temperature		110℃	<input type="radio"/>
P18.21	Low temperature protection threshold		-10℃	<input type="radio"/>
P18.22	Power correction coefficient	It is used to correct P19.10. Setting range: 0%–200%	100%	<input type="radio"/>
P18.23	Temperature PID calculation cycle (Ts)	Set the sampling cycle of temperature PID Setting range: 0.0–10.0s	2.0s	<input type="radio"/>
P18.24	Gain coefficient (kp)	It determines the adjustment intensity of temperature PID regulator. The larger the kp, the stronger the intensity, however, too strong the intensity may cause temperature oscillation. It is viable to make adjustment based on factory value according to actual conditions. Setting range: 0.0–100.0	18.0	<input type="radio"/>
P18.25	Convergence coefficient (K)	It determines the convergence speed of temperature, PID regulator. The larger the value of K, the stronger the intensity, however, too	0.12	<input type="radio"/>

Function code	Name	Detailed instruction	Default value	Modify
		strong the intensity may cause temperature oscillation. It is viable to make adjustment based on factory value according to actual conditions. Setting range: 0.00–1.00		
P18.26	Upper limit of temperature PID	It is used to limit the output value of temperature PID adjustment. 100.00% corresponds to the maximum output frequency P00.03 of the fan. Setting range: 0.00–100.00%	100.00 %	○
P18.27	Lower limit of temperature PID		10.00%	○
P18.28	Lower limit voltage of PT1 (-20℃)	It is used for calibration of temperature detection circuit in the factory: Connect the resistor whose resistance corresponds to PT100 at -20℃, read the voltage value of P17.20 and input it to P18.28 Connect the resistor whose resistance corresponds to PT100 at 150℃, read the voltage value of P17.20 and input it to P18.29 Setting range: 0.00–10.00V Note: The value stays in current set value during restoring to factory value.	0.65V	○
P18.29	Upper limit voltage of PT1 (150℃)		9.70V	○
P18.30	Pressure value of descending of upper limit frequency	0.00–P18.04 When current pressure is larger than this pressure value, decrease the upper limit frequency according to P18.31	0.70Mpa	○
P18.31	Reduction rate of upper limit frequency	0.00Hz–10.00Hz It is the reduction quantity of the corresponding upper limit frequency for each additional 0.01Mpa when current pressure is larger than P18.30.	0.00Hz	○
P18.32	Lower limit voltage of PT2 (-20℃)	It is used for calibration of temperature detection circuit in the factory: Connect the resistor whose resistance corresponds to PT100 at -20℃, read the voltage value of P17.22 and input it to P18.32 Connect the resistor whose resistance	0.65V	○

Function code	Name	Detailed instruction	Default value	Modify
		corresponds to PT100 at 150℃, read the voltage value of P17.22 and input it to P18.33 Setting range: 0.00–10.00V Note: The value stays in current set value during restoring to factory value.		
P18.33	Upper limit voltage of PT2 (150℃)		9.70V	○
P18.34	Auxiliary temperature protection enable	0: Invalid 1: Valid	0	◎
P18.35	Auxiliary temperature pre-alarm	-20–150 When P18.34 is enabled and the auxiliary temperature exceeds P18.35, the system releases auxiliary temperature pre-alarm by changing BIT8 of P19.14 to 1	105℃	○
P18.36	Auxiliary temperature alarm	-20–150 When P18.34 is enabled and the auxiliary temperature exceeds P18.36, system releases auxiliary temperature alarm by changing BIT10 of P19.14 to 1 and emergency stop will be applied.	110℃	○
P18.37	Pressure sensor channel	0: Exhaust pressure P1, auxiliary pressure P2 1: Exhaust pressure P2, auxiliary pressure P1	0	◎
P18.38	Upper limit of pressure sensor P2	0.00–20.00 Mpa It is related to the actual range of pressure sensor. The voltage corresponds to P18.04 is P05.44 Note: This value will stay in current set value during restoring to factory value.	1.60Mpa	◎
P18.39	Auxiliary pressure protection enable	0: Invalid 1: Valid	0	◎
P18.40	Auxiliary pressure pre-alarm	0.00–20.00 When auxiliary pressure protection function P19.39 is enabled, and auxiliary pressure is larger than P18.40, system releases auxiliary pressure pre-alarm by changing BIT7 of P19.14 to 1.	0.90Mpa	○
P18.41	Auxiliary pressure alarm	0.00–20.00 When auxiliary pressure protection function P19.39 is enabled and auxiliary pressure is	1.00Mpa	○

Function code	Name	Detailed instruction	Default value	Modify
		larger than P18.41, system releases auxiliary pressure alarm by changing BIT9 of P19.14 to 1 and emergency stop will be applied.		
P18.42	Reference mode of fan frequency	0: Temperature PID 1: Analog P2 2: 485 communication (address 0X201C, writing of 1000 corresponds to 100.0%, 100.0% corresponds to the max. output frequency of the fan)	0	☉
P18.43	Fan control mode	0: Air compressor mode, the fan inverter starts and stops automatically based on the temperature 1: Terminal, the fan inverter starts and stops by enabling terminals. 2: 485 communication (address 0X201B, write 1 to start, write 3 to stop)	0	☉
P18.44	Automatic frequency-reduction threshold	0–120% Add automatic frequency reduction function. When output current is larger than automatic frequency reduction threshold, output frequency will be adjusted by the regulator to ensure the running current of the master will not exceed automatic frequency reduction threshold.	120%	○
P18.45	Time-out time of maintenance	0–8000h When this parameter is set to “0”, the maintenance time-out function is invalid. If it is set to non-zero value, then the system will release maintenance time-out pre-alarm by changing BIT11 of P19.14 to 1 in cases where the working time, after part maintenance pre-alarm, exceeds the value set by P18.45.	0	○
P19.00	The set time of maintenance on part 1	P19.00–P19.04 displays the set value of maintenance time on five kinds of parts. When the accumulated working time of the part exceeds the corresponding set value, the system will release pre-alarm by changing the BIT of P19.14 to 1. If set to “0”, working time pre-alarm of the parts will be invalid.	0	●

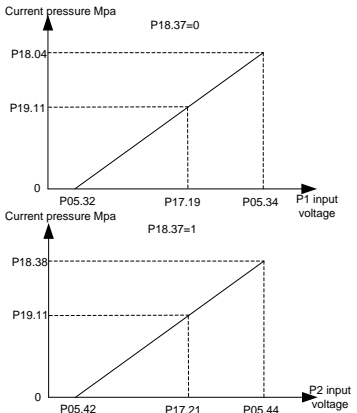
Function code	Name	Detailed instruction	Default value	Modify
		P19.05–P19.09 displays the working time of corresponding parts. Range: 0–65535h		
P19.01	The set time of maintenance on part 2		0	●
P19.02	The set time of maintenance on part 3		0	●
P19.03	The set time of maintenance on part 4		0	●
P19.04	The set time of maintenance on part 5		0	●
P19.05	Working time of part 1		0	●
P19.06	Working time of part 2		0	●
P19.07	Working time of part 3		0	●
P19.08	Working time of part 4		0	●
P19.09	Working time of part 5		0	●
P19.10	Actual output power of motor	It displays the output frequency of the motor and can be calibrated by setting P18.22 Range: 0.0–6553.5kW	0.0kW	●
P19.11	Current pressure	Displays the exhaust pressure value detected currently  <p>Range: 0.00–655.35Mpa</p>	0.00Mpa	●
P19.12	Current temperature	It displays the head temperature currently detected.	0℃	●

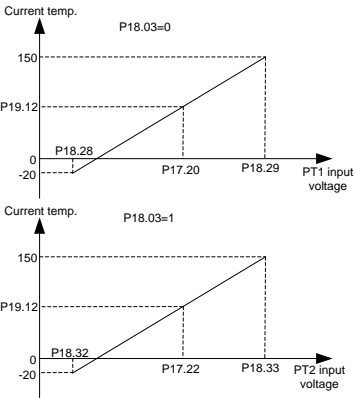
Function code	Name	Detailed instruction	Default value	Modify
		 <p>Current temp. P18.03=0</p> <p>Current temp. P18.03=1</p> <p>Range: -20~150℃</p>		
P19.13	Signal state 1	0000~0xFFFF BIT0: Air filter block signal 1: Fault; 0: normal BIT1: Oil filter block signal 1: Fault; 0: normal BIT2: Separator block signal 1: Fault; 0: Normal BIT3: Splitter block signal 1: Fault; 0: normal BIT4: External fault signal 1 1: Fault; 0: normal BIT5: External fault signal 2 1: Fault; 0: normal BIT6: Solenoid valve signal state 1: Fault; 0: normal BIT7: Auxiliary motor state 1: Run; 0: Stop BIT8: Pressure pre-alarm signal 1: Pressure pre-alarm; 0: normal BIT9: Temperature pre-alarm signal 1: Temperature pre-alarm; 0: normal BIT10: Pressure alarm signal 1: Pressure alarm; 0: normal BIT11: Temperature alarm signal	0	●

Function code	Name	Detailed instruction	Default value	Modify
		1: Temperature alarm; 0: normal BIT12: Pressure signal 1: Pressure signal fault; 0: normal BIT13: Temperature signal 1: Temperature signal fault; 0: normal BIT14: Low temperature protection 1: Low temperature alarm; 0: normal BIT15: Master state 1: Run; 0: Stop		
P19.14	Signal state 2	0-0xFFFF BIT0: Maintenance reminder of part 1 1: needs maintenance; 0: normal BIT1: Maintenance reminder of part 2 1: needs maintenance; 0: normal BIT2: Maintenance reminder of part 3 1: needs maintenance; 0: normal BIT3: Maintenance reminder of part 4 1: needs maintenance; 0: normal BIT4: Maintenance reminder of part 5 1: needs maintenance; 0: normal BIT5: Auxiliary pressure signal 1: auxiliary pressure signal fault; 0: normal BIT6: Auxiliary temperature signal 1: auxiliary temperature signal fault; 0: normal BIT7: Auxiliary pressure pre-alarm signal 1: Pressure pre-alarm; 0: normal BIT8: Auxiliary temperature pre-alarm signal 1: temperature pre-alarm; 0: normal BIT9: Auxiliary pressure alarm signal 1: pressure alarm; 0: normal BIT10: Auxiliary temperature alarm signal 1: temperature alarm; 0: normal BIT11: Maintenance time-out reminder 1: maintenance time-out reminder; 0: normal BIT12: Phase sequence reminder 1: fault; 0: normal	0	●
P19.15	Device state	0: Stand-by 1: Run	0	●

Function code	Name	Detailed instruction	Default value	Modify
		2: Fault 3: Emergency-stop 4: Under-voltage 5: Alarm 6: Sleep 7: Stopping 8: Restart delay		
P19.16	Accumulated running time of the device	Display range: 0–65535h	0	●
P19.17	Accumulated loading running time		0	●
P19.18	Restart count down	It displays the residue time of restart delay. The system enters restart delay state and restart count down after stop to prevent restart immediately. After restart delay time is passed, the system enters stand-by state and it can receive starting command in stand-by state. Range: 0–3600s	0s	●
P19.19	Temperature PID output value	It displays the output value of head temperature PID control adjustment. 100.00% corresponds to the maximum output frequency P00.03 of the fan. Range: 0.00–100.00%	0.00%	●
P19.20	Current auxiliary pressure	It displays the auxiliary pressure value detected currently	0.00Mpa	●

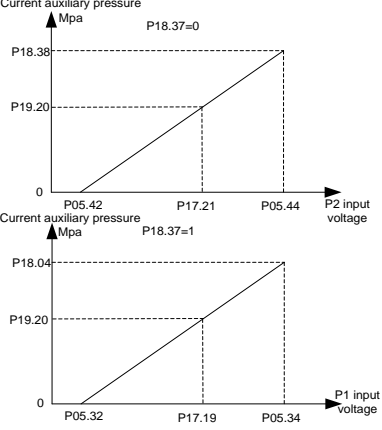
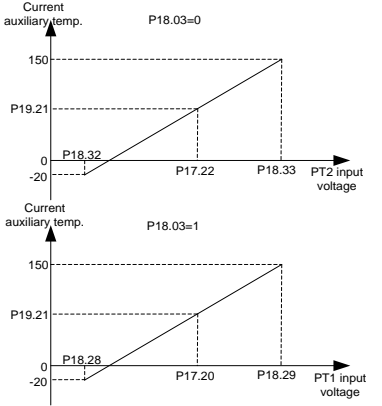
Function code	Name	Detailed instruction	Default value	Modify
		<p>Current auxiliary pressure</p>  <p>Range: 0.00–655.35Mpa</p>		
P19.21	Current auxiliary temperature	<p>It displays the auxiliary temperature value detected currently</p>  <p>Range: -20 – 150℃</p>	0℃	●
P19.22	Phase sequence state of input power	<p>If phase sequence detection and input phase loss hardware protection are enabled, the inverter will report fault when negative sequence and any phase loss occurred. If they are not enabled, the inverter will not report the fault. 0: positive sequence 1: negative sequence</p>	0	●

Function code	Name	Detailed instruction	Default value	Modify
		2: lack of R phase 3: lack of S phase 4: lack of T phase		

5.3. Instruction of air compressor control logic

(1) The control logic of air compressor is shown as below:

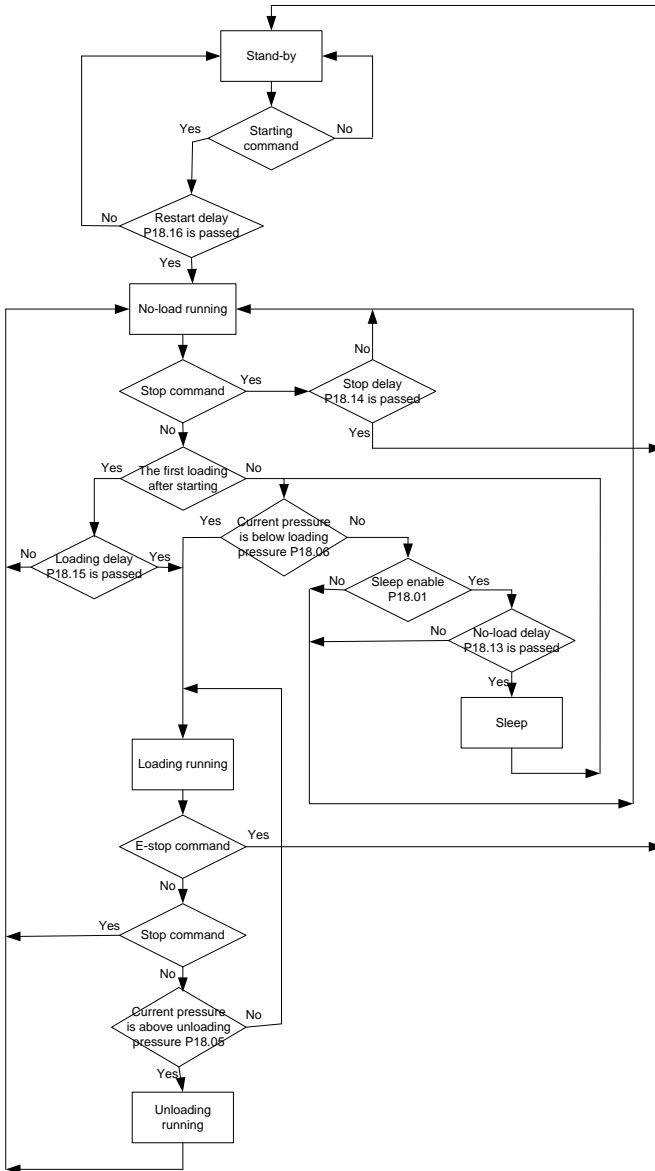

(2) The pressure and running frequency control of air compressor during running is shown as below:

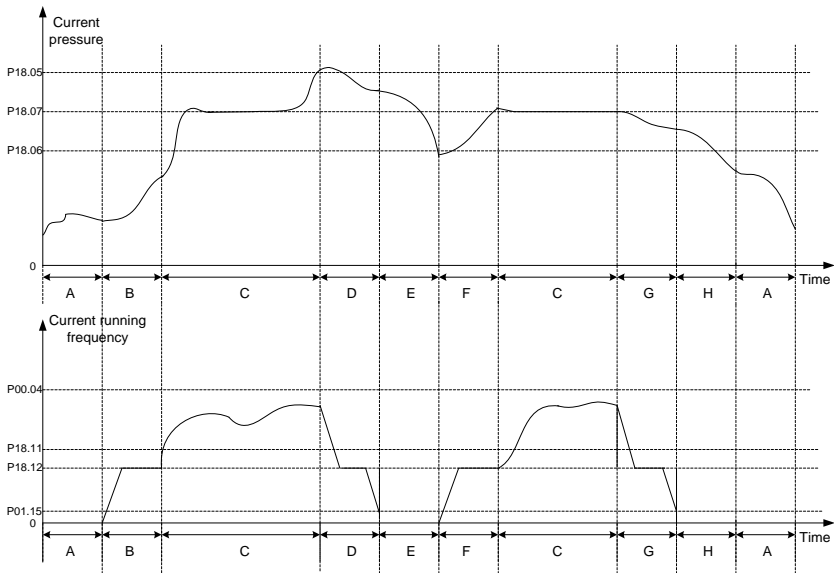

In above figure, P18.05 is unloading pressure, P18.06 is loading pressure and P18.07 is the set pressure.

P00.04 is upper limit frequency, P18.11 is lower limit value of loading running frequency, P18.12 is no-load frequency and P01.15 is stop speed. In the figure, the process instruction for A–H stages are listed as below:

- A: Stand-by state
- B: Beginning stage of starting, the duration time is P18.15 (including part of ACC time P00.11)
- C: Constant pressure exhaust stage of loading, pressure PID adjustment is valid
- D: Unloading stage, the duration time includes part of DEC time P00.12 and P18.13
- E: Sleep stage, the inverter does not run
- F: Wake-up and starting stage, the duration time is P18.15 (including part of ACC time P00.11)
- G: Beginning of stop, the duration time includes part of DEC time P00.12 and P18.14
- H: Restart delay stage after stop, the duration time is P18.16

When air compressor control is valid, its air supply will be normal after it starts in automatic loading/unloading mode. When the exhaust pressure is detected to be above P18.05, automatic unloading will be applied. If sleep function is valid, the inverter will enter sleep state. While if sleep function is invalid, the inverter will run continuously at no-load frequency P18.12. When the exhaust

pressure is detected to be below P18.06, automatic loading will be applied. During loading running, the rotation speed of the master will be controlled by pressure PID. P18.07 is the air supply pressure when setting stable running of air compressor, the inverter keeps exhaust pressure constant by regulating the rotation speed of the master. Constant pressure control adopts PID algorithm, and the frequency reference source of the master is set by P00.06=7, the reference source of PID is P09.00=10, the reference pressure is set by P18.07. The feedback source of PID is P09.02=8, which is gained by detecting pressure signal. P9.04, P9.05 and P9.06 adopts system default values.

Note: In above figure, the stop mode of the inverter is operated by P01.08, the default setting is decelerating to stop.

The inverter is in deceleration process under normal stop command and unloading stage; it changes to coast to stop mode when emergency stop or fault occur.

6. Fault information and solution

6.1. Faults and countermeasures for integrated machine

Table 6.1 Faults and countermeasures for Goodrive300-21 air compressor integrated machine

Fault code	Fault type	Possible cause	What to do
OUt1	Inverter unit Ph-U protection	<ul style="list-style-type: none"> ● The acceleration is too fast ● IGBT of this phase is damaged internally 	<ul style="list-style-type: none"> ● Increase Acc time ● Replace the power unit
OUt2	Inverter unit Ph-V protection	<ul style="list-style-type: none"> ● Mis-action caused by interference 	<ul style="list-style-type: none"> ● Check the driving wires ● Inspect peripheral equipment and eliminate interference
OUt3	Inverter unit Ph-W protection	<ul style="list-style-type: none"> ● The connection of the driving wires is not good, ● Grounding short circuit occur 	<ul style="list-style-type: none"> ● Check the input power ● Check if the DEC time of the load is too short or the inverter starts during the rotation of the motor or it needs to add the dynamic braking components
OV1	Over-voltage at acceleration	<ul style="list-style-type: none"> ● The input voltage is abnormal ● There is large energy feedback 	<ul style="list-style-type: none"> ● Check the input power ● Check if the DEC time of the load is too short or the inverter starts during the rotation of the motor or it needs to add the dynamic braking components
OV2	Over-voltage at deceleration		
OV3	Over-voltage at constant speed running		
OC1	Over-current at acceleration	<ul style="list-style-type: none"> ● The acceleration or deceleration is too fast ● The voltage of the grid is too low ● The power of the inverter is too low ● The load transients or is abnormal ● The grounding is short circuited or the output is phase loss ● There is strong external interference 	<ul style="list-style-type: none"> ● Increase the ACC/DEC time ● Check the input power ● Select the inverter with a larger power ● Check if the load is short circuited (the grounding short circuited or the wire short circuited) or the rotation is not smooth ● Check the output configuration. ● Check if there is strong interference
OC2	Over-current at deceleration		
OC3	Over-current at constant speed running		
UV	DC bus Under-voltage	<ul style="list-style-type: none"> ● The voltage of the power grid is too low 	<ul style="list-style-type: none"> ● Check the input power of the grid
OL1	Motor overload	<ul style="list-style-type: none"> ● The voltage of the grid is too low ● The motor setting rated current is incorrect 	<ul style="list-style-type: none"> ● Check the voltage of the grid ● Reset the rated current of the motor

Fault code	Fault type	Possible cause	What to do
		<ul style="list-style-type: none"> ● The motor stall or load transients is too strong 	<ul style="list-style-type: none"> ● Check the load and adjust the torque lift
OL2	Inverter overload	<ul style="list-style-type: none"> ● The acceleration is too fast ● Restart the rotating motor ● The voltage of the grid is too low ● The load is too heavy 	<ul style="list-style-type: none"> ● Increase ACC time ● Avoid restarting after stopping ● Check the power of grid ● Select an inverter with a bigger power ● Select a proper motor
SPI	Input phase loss	<ul style="list-style-type: none"> ● Phase loss or fluctuation of input R,S,T 	<ul style="list-style-type: none"> ● Check input power ● Check installation wiring
SPO	Output phase loss	<ul style="list-style-type: none"> ● U,V,W phase loss output(or serious asymmetrical three phases of the load) 	<ul style="list-style-type: none"> ● Check the output wiring ● Check the motor and cable
OH1	Overheat of rectifier module	<ul style="list-style-type: none"> ● Air duct jam or fan damage ● Ambient temperature is too high 	<ul style="list-style-type: none"> ● Clean the air duct or replace the fan ● Lower down the ambient temperature
OH2	Overheat of inverter module	<ul style="list-style-type: none"> ● The time of overload running is too long 	
EF	External fault	<ul style="list-style-type: none"> ● S external fault input terminals action 	<ul style="list-style-type: none"> ● Check the external device input
CE	485 communication fault	<ul style="list-style-type: none"> ● The baud rate setting is incorrect ● Fault occurs to the communication line. ● The communication address is wrong ● There is strong interference to the communication 	<ul style="list-style-type: none"> ● Set proper baud rate ● Check the wiring of communication interface ● Set proper communication address ● Chang or replace the wiring to improve anti-interference capability
ItE	Current detection fault	<ul style="list-style-type: none"> ● The connection of the control board is not good ● Hall components is broken ● The modifying circuit is abnormal 	<ul style="list-style-type: none"> ● Check the connector and re-wiring ● Replace the hall ● Replace main control panel
tE	Motor autotuning fault	<ul style="list-style-type: none"> ● The motor capacity does not match the inverter capacity ● The rated parameter of the motor does not set correctly. ● The deviation between the 	<ul style="list-style-type: none"> ● Change the inverter model ● Set the rated parameter according to the motor nameplate

Fault code	Fault type	Possible cause	What to do
		parameters gained from autotuning and the standard parameter is huge <ul style="list-style-type: none"> ● Autotune overtime 	<ul style="list-style-type: none"> ● Empty the motor load and re-identify ● Check the motor connection and set the parameter. ● Check if the upper limit frequency is above 2/3 of the rated frequency.
EEP	EEPROM fault	<ul style="list-style-type: none"> ● Error occurred to the writing/reading of control parameters ● Damage to EEPROM 	<ul style="list-style-type: none"> ● Press STOP/RST to reset ● Replace the main control panel
PIDE	PID feedback disconnection fault	<ul style="list-style-type: none"> ● PID feedback disconnection ● PID feedback source disappears 	<ul style="list-style-type: none"> ● Check the PID feedback signal line ● Check the PID feedback source
END	Running time is up	<ul style="list-style-type: none"> ● The actual running time of the inverter is longer than the internal set running time 	<ul style="list-style-type: none"> ● Ask help from the supplier, adjust the set running time
OL3	Electric overload fault	<ul style="list-style-type: none"> ● The inverter releases overload pre-alarm according to the set value 	<ul style="list-style-type: none"> ● Check the load and overload pre-alarm threshold
PCE	Keypad communication fault	<ul style="list-style-type: none"> ● Poor contact of keypad wire or disconnection occurred ● The keypad wire is too long and suffers from strong interference ● Circuit fault occurred to keypad or communication part of the main board 	<ul style="list-style-type: none"> ● Check the keypad wires and check if there is fault ● Check the environment and rule out interference source ● Replace the hardware and ask for service
UPE	Parameter uploading error	<ul style="list-style-type: none"> ● Poor contact of keypad wire or disconnection occurred ● The keypad wire is too long and suffers from strong interference ● Circuit fault occurred to keypad or communication part of the main board 	<ul style="list-style-type: none"> ● Check the environment and rule out interference source ● Replace the hardware and ask for service ● Replace the hardware and ask for service
DNE	Parameters	<ul style="list-style-type: none"> ● Poor contact of keypad wire or 	<ul style="list-style-type: none"> ● Check the environment

Fault code	Fault type	Possible cause	What to do
	downloading error	<p>disconnection occurred</p> <ul style="list-style-type: none"> ● The keypad wire is too long and suffers from strong interference ● There is mistake on the data storage of the keypad 	<p>and rule out interference source</p> <ul style="list-style-type: none"> ● Replace the hardware and ask for service ● Re-copy the data in the keypad
ETH1	Grounding short circuit fault 1	<ul style="list-style-type: none"> ● The output of the inverter is short circuited with the ground ● Fault occurred to current detection circuit 	<ul style="list-style-type: none"> ● Check if the motor connection is normal or the motor is short circuited to the ground ● Replace the hall ● Replace the main control panel/drive board
ETH2	Grounding short circuit fault 2		
dEu	Velocity deviation fault	<ul style="list-style-type: none"> ● The load is too heavy or stalled 	<ul style="list-style-type: none"> ● Check the load and ensure it is normal ● Increase the detection time ● Check whether the control parameters are proper
STo	Maladjustment fault	<ul style="list-style-type: none"> ● The control parameters of the synchronous motors is set improperly ● The autotuning parameter is not right ● The inverter is not connected to the motor 	<ul style="list-style-type: none"> ● Check the load and ensure it is normal ● Check whether the control parameter is set properly ● Increase the maladjustment detection time
LL	Electronic underload fault	<ul style="list-style-type: none"> ● The inverter reports the underload pre-alarm according to the set value 	<ul style="list-style-type: none"> ● Check the load and the underload pre-alarm point
E_FAN	Auxiliary fan fault	<ul style="list-style-type: none"> ● Fault occurred to fan inverter 	<ul style="list-style-type: none"> ● Fault code of fan inverter can be viewed from the touch screen as shown in fig 6.1
PSF	Phase sequence fault	<ul style="list-style-type: none"> ● The phase sequence on the input side of the power is negative 	<ul style="list-style-type: none"> ● Swap any two power input cables
	Communication interruption	<ul style="list-style-type: none"> ● 485 communication port is disconnected 	<ul style="list-style-type: none"> ● Check if the communication cable is loose or dropped



Fig 6.1 E_FAN fault display interface

Click “menu” in fig 6.1 interface, and the interface is shown in Fig 4.8;

Click “platform information” in the interface and the interface is shown in below fig:



Click “keypad” on the right side of the “fan” to enter virtual keypad interface of the fan. Input P07.27–P07.32 in “function code address” to inquire concrete fault code as shown below:



Deal with the fault code displayed in the virtual keypad according to the fault countermeasures listed in Table 6.1.

6.2. Fault and countermeasures for air compressor device

Fault and countermeasures for air compressor device are listed as below:

P19.13	State type	Possible cause	Corrective measures
BIT0=1	Air filter is blocked	Air filter is abnormal	Stop and check the air filter
BIT1=1	Oil filter is blocked	Oil filter is abnormal	Stop and check the oil filter
BIT2=1	Separator is blocked	Separator is abnormal	Stop and check the separator
BIT3=1	Splitter is blocked	Splitter is abnormal	Stop and check the splitter
BIT8=1	Pressure pre-alarm	The actual pressure detected by P1 is larger than the pre-alarm pressure set by P18.17	Check if solenoid valve is normal; Check if pressure control parameters are set correctly
BIT9=1	Temperature pre-alarm	The actual temperature detected by PT1 is larger than the pre-alarm temperature set by P18.19	Check if control parameters of the fan are set correctly; Check if the fan operates normally; The fan power is too small for effective cooling; Check if there is lubricating oil
BIT10=1	Pressure alarm	The actual pressure detected by P1 is larger than the alarm pressure set by P18.18	Check if solenoid valve is normal; Check if pressure control parameters are set correctly
BIT11=1	Temperature	The actual temperature	Check if control parameters of the fan

P19.13	State type	Possible cause	Corrective measures
	alarm	detected by PT1 is larger than the alarm temperature set by P18.20	are set correctly; Check if the fan operates normally; The fan power is too small for effective cooling; Check if there is lubricating oil
BIT12=1	Pressure signal fault	The actual pressure detected by P1 is less than 1V	Check if pressure detection sensor is abnormal; The input P1 signal wire of pressure detection is dropped; The pressure signal interface does not select current signal
BIT13=1	Temperature signal fault	PT100 sensor is disconnected	Check if the wiring of PT100 is normal; Temperature detection sensor is abnormal; Temperature detection circuit is abnormal
BIT14=1	Low temperature protection pre-alarm	The actual temperature detected by PT1 is less than the low temperature protection threshold set by P18.21	Temperature detection sensor is abnormal; Temperature detection input circuit is abnormal The actual temperature is too low. So low temperature pre-alarm is released as normal to prevent air compressor from starting.

P19.14	State type	Possible cause	Corrective measures
BIT0=1	Part 1 needs maintenance	The running time of part 1 exceed the set time of P19.00	Stop and carry out maintenance
BIT1=1	Part 2 needs maintenance	The running time of part 2 exceed the set time of P19.01	Stop and carry out maintenance
BIT2=1	Part 3 needs maintenance	The running time of part 3 exceed the set time of P19.02	Stop and carry out maintenance
BIT3=1	Part 4 needs maintenance	The running time of part 4 exceed the set time of P19.03	Stop and carry out maintenance
BIT4=1	Part 5 needs maintenance	The running time of part 5 exceed the set time of P19.04	Stop and carry out maintenance
BIT5=1	Auxiliary pressure signal fault	The actual pressure detected by P2 is less than 1V	The pressure detection sensor is abnormal; The P2 signal wire of pressure

P19.14	State type	Possible cause	Corrective measures
			detection is dropped
BIT6=1	Auxiliary temperature signal fault	PT100 sensor is disconnected	Detect if PT100 wiring is normal Temperature detection sensor is abnormal Temperature detection input circuit is abnormal
BIT7=1	Auxiliary pressure pre-alarm	The actual pressure detected by P2 is larger than the pre-alarm pressure set by P18.17	Pressure detection sensor is abnormal; The set value of pressure is too large; Adjust pressure PID regulator
BIT8=1	Auxiliary temperature pre-alarm	The actual temperature detected by PT2 is larger than the pre-alarm temperature set by P18.19	Temperature detection sensor is abnormal; Temperature detection input circuit is abnormal; The starting temperature of the fan is set to high; The fan power is too low for effective cooling
BIT9=1	Auxiliary pressure alarm	The actual pressure detected by P2 is larger than the pressure alarm set by P18.18	Pressure detection sensor is abnormal; The set value of pressure is too large; Adjust pressure PID regulator
BIT10=1	Auxiliary temperature alarm	The actual temperature detected by PT2 is larger than the pre-alarm temperature set by P18.20	Temperature detection sensor is abnormal; Temperature detection input circuit is abnormal; The starting temperature of the fan is set to high; The fan power is too low for effective cooling
BIT11=1	Maintenance time-out alarm	Any part whose working time exceeds the set time will enter time-out maintenance stage, then if its working time exceeds the time set by P18.45, system will release alarm.	Conduct maintenance on time-out parts after stop.

Appendix A. Product dimension

A.1. Wall installation dimension

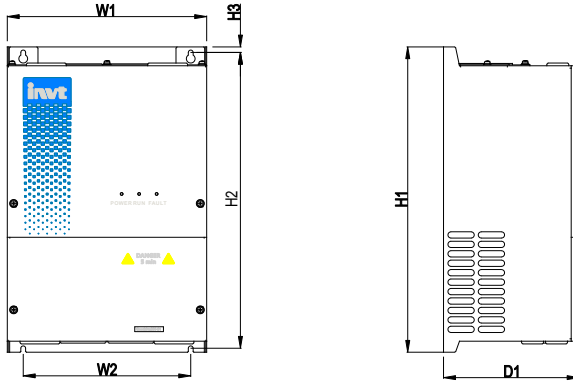

Fig A.1 Wall installation diagram for 220V 7.5–18.5kW/380V 15–37kW

Table A.1 Wall installation dimension for 220V 7.5–18.5kW/380V 15–37kW (unit: mm)

Inverter specification	W1	W2	H1	H2	H3	D1	Diameter of installation bore
220V 7.5–11kW 380V 15–22kW	250	210	388	377	7	170	6
220V 15–18.5kW 380V 30–37kW	300	210	438	426	8	190	6

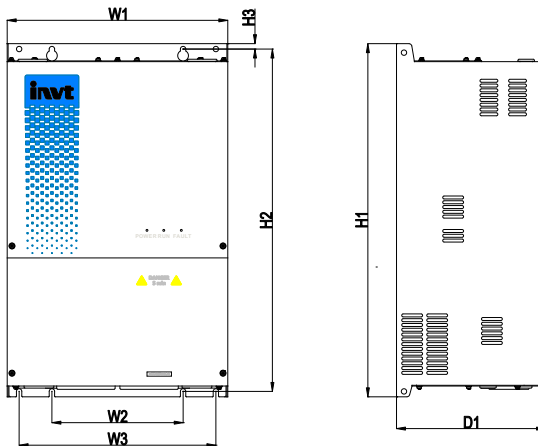

Fig A.2 Wall installation diagram for 220V 22–45kW/380V 45–90kW

Table A.2 Wall installation dimension for 220V 22–45kW/380V 45–90kW (unit: mm)

Inverter specification	W1	W2	W3	H1	H2	H3	D1	Diameter of installation bore
220V 22–45kW 380V 45–90kW	370	220	330	590	572	9	250	9

A.2. Floor installation dimension (with top cover)

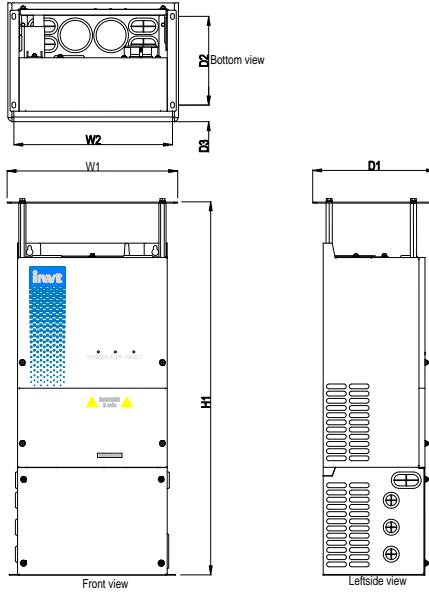

Fig A.3 Floor installation (with top cover) for 220V 7.5–45kW/380V 15–90kW

Table A.3 Floor installation (with top cover) dimension for 220V 7.5–45kW/380V 15–90kW (unit: mm)

Inverter specification	W1	W2	H1	D1	D2	D3	Diameter of installation bore
220V 7.5–11kW 380V 15–22kW	285	265	623	205	148	28	6
220V 15–18.5kW 380V 30–37kW	335	315	682	225	158	33	6
220V 22–45kW 380V 45–90kW	405	388	884	285	160	65	9

Note: Top cover must be selected together with the pedestal, namely floor installation (with top cover), in addition, wall installation will be unavailable when installing the top cover.

A.3. Floor installation dimension (without top cover)

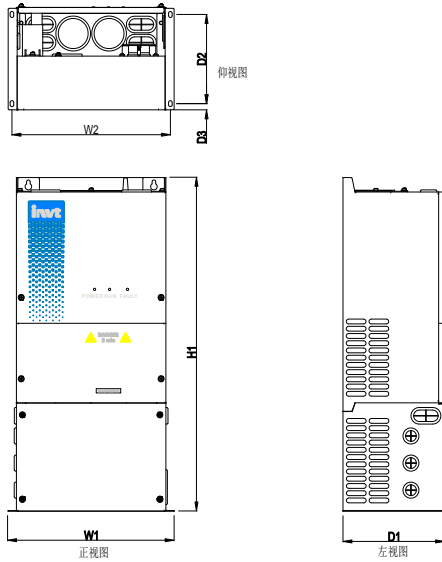

Fig A.4 Floor installation (w/o top cover) for 220V 7.5–45kW/380V 15–90kW

Table A.4 Floor installation (w/o top cover) dimension for 220V 7.5–45kW/380V 15–90kW (unit: mm)

Inverter specification	W1	W2	H1	D1	D2	D3	Diameter of installation bore
220V 7.5–11kW 380V 15–22kW	278	265	555	180	148	10	6
220V 15–8.5kW 380V 30–37kW	328	315	604	190	158	15	6
220V 22–45kW 380V 45–90kW	404	388	812	250	160	44	9

A.4. Product weight and packaging dimension

Product weight	N.W(kg)	G.W (kg)	Packaging dimension (mm)
220V 7.5–11kW/380V 15–22kW (integrated machine)	15	18	515x385x320
220V 15–18.5kW/380V 30–37kW (integrated machine)	22	24	585x435x340
220V 22–37kW/380V 45–75kW (integrated machine)	38	42	725x490x410
220V 45kW/380V 90kW (integrated machine)	42	45	725x490x410

Product weight	N.W(kg)	G.W (kg)	Packaging dimension (mm)
220V 7.5–11kW/380V 15–22kW (top cover)	0.7	1	310x220x35
220V 15–18.5kW/380V 30–37kW (top cover)	1	2	360x240x40
220V 22–45kW/380V 45–90kW (top cover)	1.5	2.5	430x295x35
220V 7.5–11kW/380V 15kW–22kW (Pedestal)	1.8	3	370x245x290
220V 15–18.5kW/380V 30–37kW (Pedestal)	2	3	420x265x270
220V 22–45kW/380V 45–90kW (Pedestal)	4	5.5	520x360x370

Appendix B. Optional parts and accessories

Accessories	Installation position
Power consumption detection component	Externally installed during wall installation, and built-in installation can be available if the optional floor stand is installed.
Contact component	Externally installed during wall installation, and built-in installation can be available if the optional floor stand is installed.
Remote data collection terminal	Built-in
Drip-proof top cover	External
Floor installation pedestal	External
Touch screen	Installed on the panel of air compressor

B.1. Power consumption component

The precision of power consumption detection function carried by Goodrive300-21 is about 5%. It can act as the basis for estimation of power consumption. If high-precise power detection is needed, it is recommended to install the optional power detection component (1% precision with national professional certification) to monitor the power factor and power consumption of air compressor.

B.1.1. Open-package inspection

Please carefully check if the product package is intact before open-package inspection. If any question, please contact the supplier immediately.

Name	Model	Qty.	Remark
Current transformer	AKH-0.66/Z-20 100/5A	1	AC220V 7.5–18.5kW AC380V 15–37kW
	AKH-0.66/Z-20 200/5A		AC220V 22–37kW AC380V 45–75kW
Power collection module	HC-33B	1	/
Fixed parts	/	1	/
Connection cable of power collection module component	/	1	/
Combination screw	M4x10	2	Fixing the current transformer
Ribbon	/	10	Fixing cables

B.1.2. Guidance on electrical wiring

Goodrive300-21 power detection component is comprised of current transformer and current collection module. Its electrical wiring diagram is shown as below:

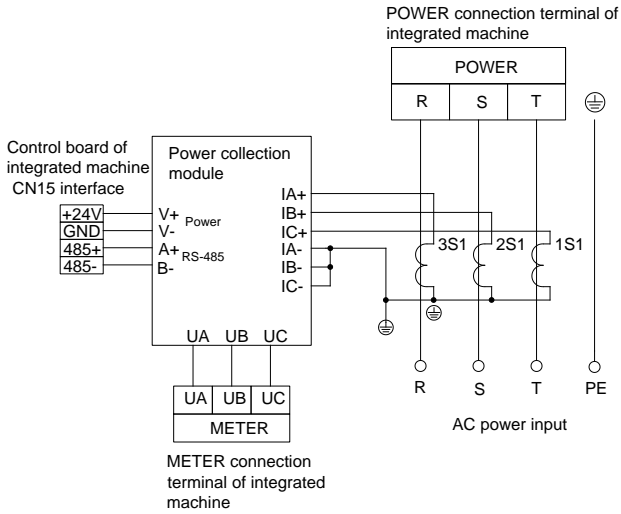

Fig B.1 Wiring diagram of power detection component

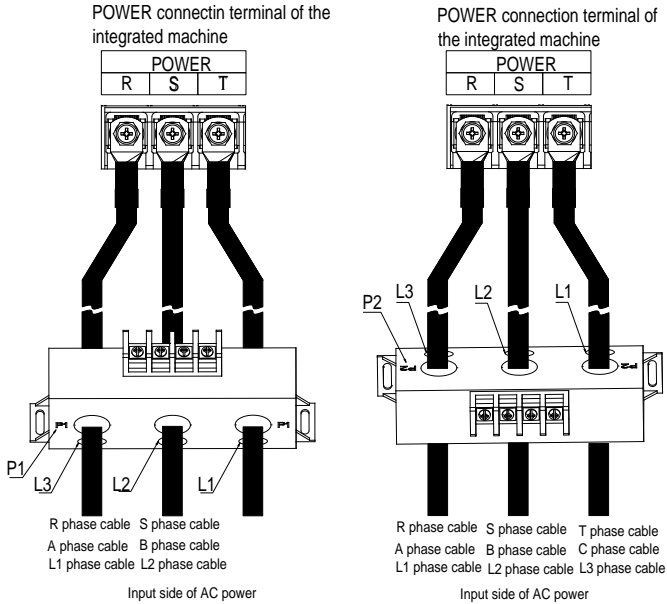



Fig B.2 Wiring diagram of current transformer

When installing current transformer, the user should pay attention to below points:

1. The cable on AC power input side should go through P1 side of the transformer and goes out from P2 side;
2. R phase should go through L3 hole, S phase through L2 hole and T phase through L1 hole;
3. L3 hole corresponds to the terminal 3S1 on secondary side, L2 to the 2S1 on secondary side and L1 to the 1S1 on secondary side.  is common port.

B.1.3. Dimension of power detection component

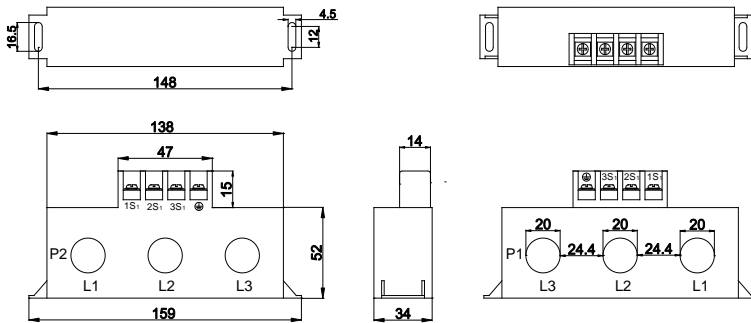

Fig B.3 Dimension of 15–75kW current transformer (unit: mm)

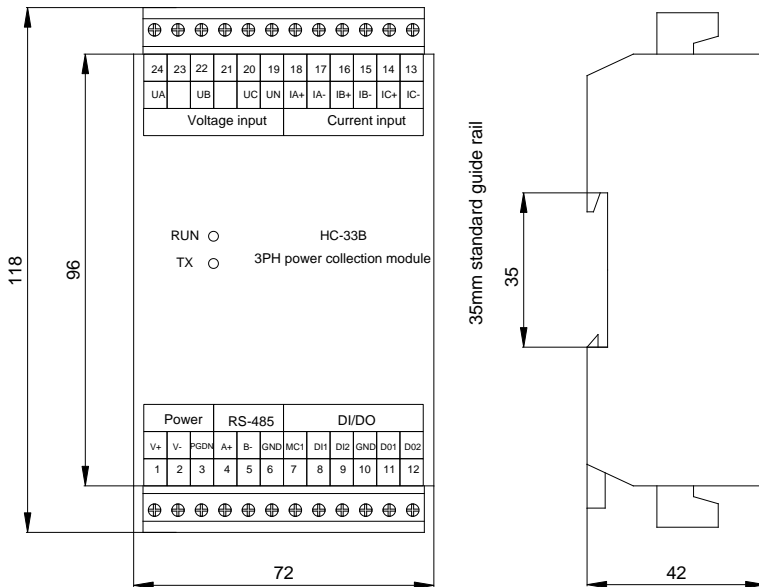

Fig B.4 Dimension of power collection module (unit: mm)

B.1.4. Debugging

1. Installing and wiring according to the requirements described in B.1.1, B.1.2 and B.1.3. After confirming the installation and wiring is correct, click start button in “system configuration” page on the touch screen to enable ammeter function.

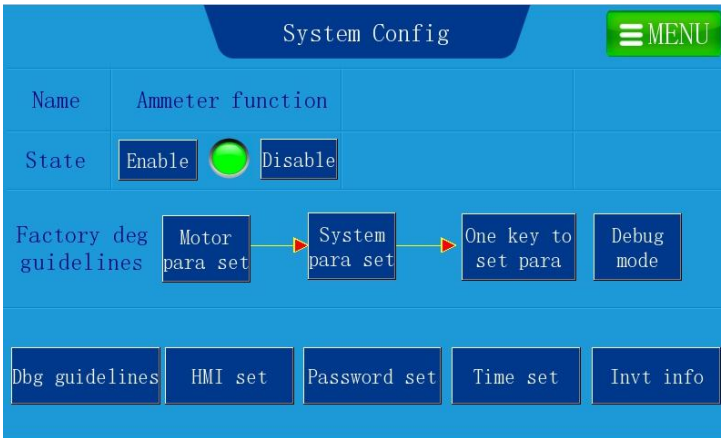

Fig B.5 System configuration interface

2. Then, click “menu” →“user parameter” →“Ammeter function”, observe whether voltage/current display is normal.



Fig B.6 Power detection information display interface

Note: Parameters displayed in fig B.6 are for reference only and should subject to actual displayed content.

B.2. Contactor component

When the main motor and its cooling fan is connected in non-coaxial way, it is recommended to install the optional contactor component to control the operation of main motor cooling fan. The optional contactor component is available from our company.

B.2.1. Open package inspection

Please carefully check if the product package is intact before open-package inspection. If any question, please contact the supplier immediately.

Name	Model	Qty.	Remark
Contactor	CJX2-0910M380V 9A; Coil voltage 220VAC	1	/
	CJX2-0910F 380V 9A; Coil voltage 110VAC		
3pin conversion terminal	TB-2503L	1	/
Fuse	RO15 690V 2A	2	/
Fuse pedestal	RT14-20/690V	2	/
Fixed parts	/	2	/
Connection cable of contactor component	/	1	/
Pan head screws	M4x10	4	Fixing the conversion terminal and fuse pedestal
Ribbon	/	10	Fixing cables

Note: Users should select contactor coil voltage based on actual usage condition. When 110V coil is selected, it is required to adjust CN7 short-circuit terminal of the control board to CN8.

B.2.2. Guidance on electrical wiring

Goodrive300-21 contactor component is comprised of contactor and fuse. Its electrical wiring diagram is shown as below:

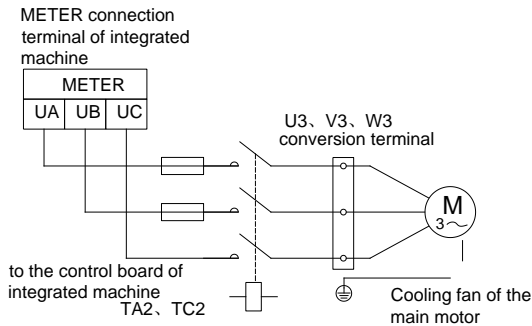

Fig B.7 Electrical diagram of contactor component

B.2.3. Installation steps for fuse pedestal

The fuse pedestal must be installed according to below procedures, otherwise any wiring attempt would failure

Step 1: Connect the cable to the bottom of the two pedestals respectively. The yellow cable (cable mark is FU-2) should be connected to the left side while the green cable (cable mark is FU-4) should be connected to the right side;

Step 2: Yellow cable goes through the through-hole on the left side and green cable goes through the through-hole on the right side;

Step 3: Put the fuse pedestal into the installation stand and fix the fuse pedestal with M4 pan head screw;

Step 4: Install the fuse into the fuse pedestal;

Step 5: Fuse pedestal installation is completed.

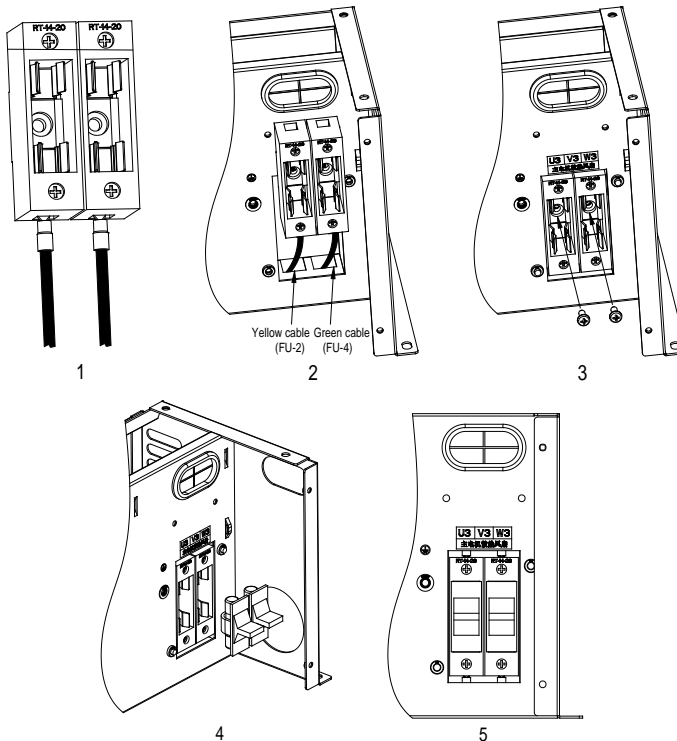

Fig B.8 Installation diagram of fuse pedestal

B.2.4. Dimension of contactor component

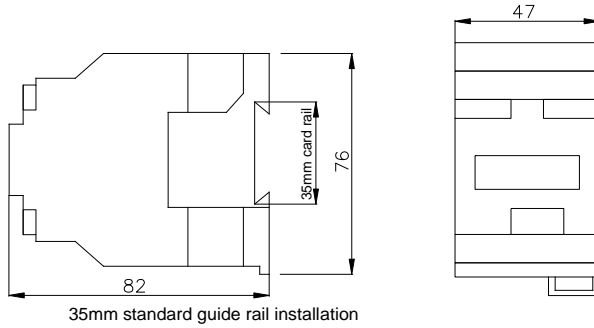

Fig B.9 Contactor dimension (unit: mm)

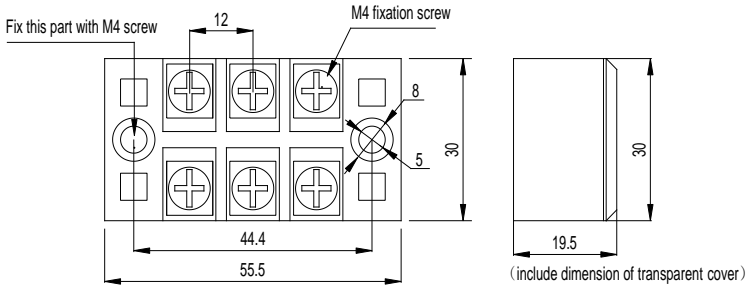

Fig B.10 Dimension of conversion terminals (unit: mm)

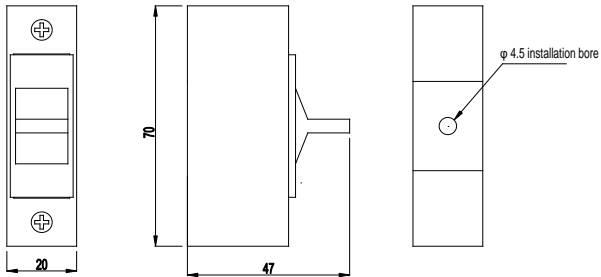

Fig B.11 Dimension of fuse pedestal (unit: mm)

B.3. Power detection component and contactor component

When users need both power detection component and contactor component, the electrical diagram is shown as below:

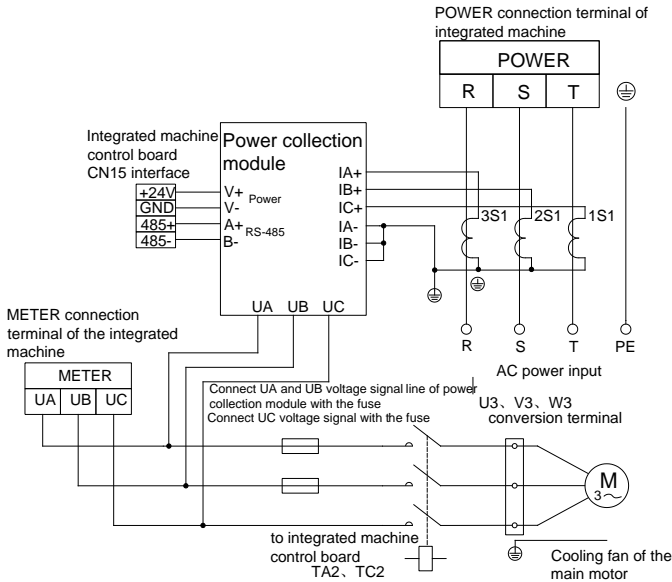

Fig B.12 Electrical diagram of power detection and contactor components

Note: When power detection and contactor components are used together, it requires only one fixed part and the two extra fixed parts can be for back-up purpose.

B.4. Remote data collection terminal component

Users can select to install remote data collection terminal to conveniently learn the operation condition of air compressor integrated machine. The remote data collection terminal collects running parameters of HMI touch screen air compressor integrated machine by RS485 and users can remotely monitor the following items via IOT monitoring interface: running state, exhaust pressure, oil gas temperature, power consumption, fault information and fault diagnosis.

B.4.1. Open package inspection

Please carefully check if the product package is intact before open-package inspection. If any question, please contact the supplier immediately.

Name	Model	Qty.	Remark
Remote data collection terminal module (with traffic card)	IOT_GPRS_0100	1	/
Antenna	5m, 700MHz-2.7GHz	1	/
24V power cable of the module	/	1	/
485 communication cable (shielded)	2m	1	/
Pan head screw	M3x6	3	Fixing remote data

Name	Model	Qty.	Remark
			collection module
Ribbon	/	5	/

B.4.2. Guidance on electrical wiring

The electrical wiring diagram of remote data collection terminal is shown as below:

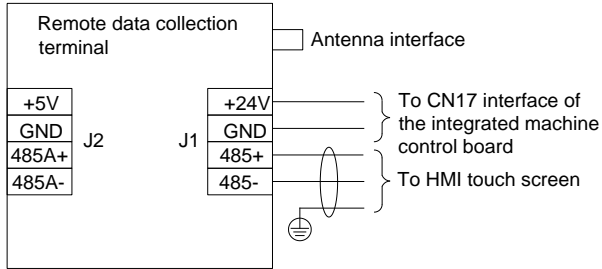

Fig B.13 Electrical wiring diagram of remote data collection terminal

Note:

1. In order to avoid electromagnetic interference, please use shielded cable to connect remote data collection terminal with HMI touch screen.
2. The +24V working power of remote data collection terminal comes from the control board of air compressor integrated machine.
3. Please place the antenna of remote data collection terminal in open space to ensure better signal transmission.

B.4.3. Dimension of remote data collection terminal component

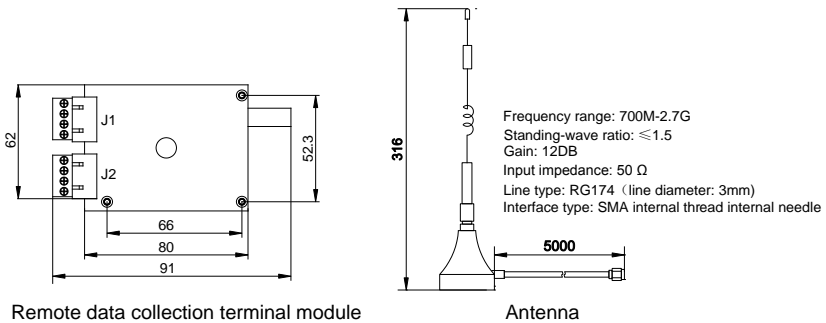

Fig B.14 Dimension of remote data collection terminal (unit: mm)

B.4.4. Debugging

Installing and wiring according to the requirements in B.4.1, B.4.2 and B.4.3. After powering up, observe the indicator of remote data collection terminal module, which should flash quickly at the beginning, then the green indicator keeps on and red indicator flashes at 15s interval. When selecting “valid” for GPRS operation enabling in “protection parameter” interface, it is viable to give reset command and modify parameters; if selecting “invalid”, state parameters will be read-only.

Users can log onto the server (iot.invt.com:10000) with the account and password provided by INVT to check whether remote data terminal module is connected to internet.

Protection Para			
Warning Press 0.00 MPa	Alarm Press 0.00 MPa	Pre-alarm Temp 0 °C	Alarm Temp 0 °C
Low Temp Prot 0 °C	GPRS enabling valid		
Aux Press Prot invalid	Current aux Press 0.00 MPa	Aux warning Press 0.00 MPa	Aux alarm Press 0.00 MPa
Aux Temp Prot invalid	Current aux Temp 0 °C	Aux warning Temp 0 °C	Aux alarm Temp 0 °C

Fig B.15 Protection parameter interface

Note:

1. Refer to IOT_GPRS_0100 product manual for detailed instruction on remote data collection terminal module.
2. Parameters displayed in fig B.15 is for reference only and should be subject to the actual displayed content.

B.5. Drip-proof top cover

In order to meet IP21 protection class, it is recommended to install optional drip-proof top cover on Goodrive300-21. The detailed package list is shown as below:

Name	Model	Qty.	Remark
Hex stud	M5x101	4	220V 7.5–11kW 380V 15–22kW
	M5x110	4	220V 15–18.5kW 380V 30–37kW
	M5x110	4	220V 22–45kW 380V 45–90kW

Name	Model	Qty.	Remark
Combination screw	M5×10	4	220V 7.5–11kW 380V 15–22kW
	M4×10	4	220V 15–18.5kW 380V 30–37kW
	M4×10	4	220V 22–45kW 380V 45– 90kW
Top cover	285×205	1	220V 7.5–11kW 380V 15–22kW
	335×225	1	220V 15–18.5kW 380V 30–37kW
	405×285	1	220V 22–45kW 380V 45– 90kW

Note:

1. Refer to A.2 for detailed dimensions
2. If users select top cover by themselves, please note that the distance between top cover and the fan should be no less than 110mm, otherwise cooling effect may be impacted.

B.5.1. Installation of drip-proof top cover

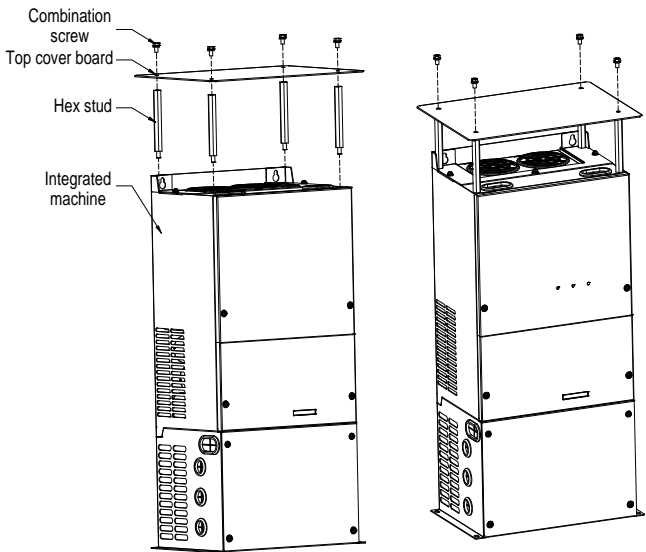

Installation diagram for optional top cover

Fig B.16 Installation diagram for drip-proof top cover

B.6. Floor installation pedestal

B.6.1. Open package list

The default installation mode for Goodrive300-21 is wall installation. If Floor installation is needed, users can install the pedestal for floor installation. The package list is shown as below:

Name	Model	Qty.	Remark
Combination screw	M5x10	4	220V 7.5–18.5kW 380V 15–37kW
	M8x16		220V 22–45kW 380V 45–90kW
Pedestal	278x170x180	1	220V 7.5–11kW 380V 15–22kW
	328x190x180		220V 15–18.5kW 380V 30–37kW
	404x250x240		220V 22–45kW 380V 45–90kW

Note:

1. Refer to A.2 and A.3 for detailed dimensions.
2. If users select pedestal by themselves, please note that the ventilation hole size of the pedestal should be no less than 1.2 times of the ventilation hole size at the bottom of integrated machine.

B.6.2. Installation diagram of the pedestal

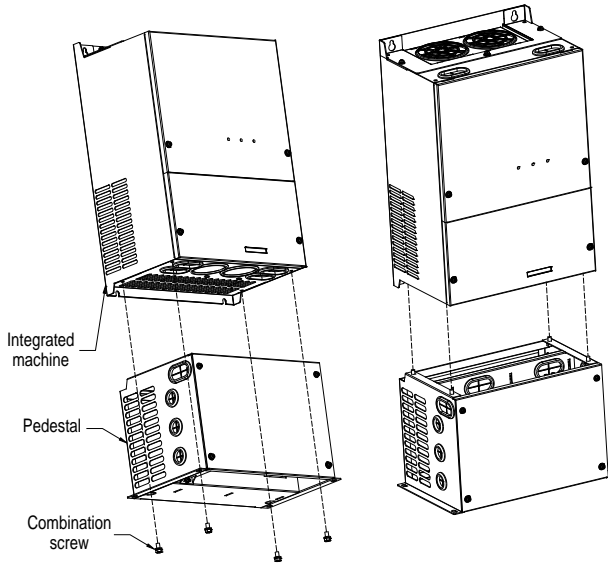

Fig B.17 Installation diagram of the pedestal

Note: If users need to install power detection component or contactor component, it is recommended to install the components onto the pedestal first, then, install the pedestal onto the integrated machine.

B.6.3. Installation diagram of optional pedestal

Please refer to below diagram if it is needed to install optional power detection component and contactor component onto the installation pedestal.

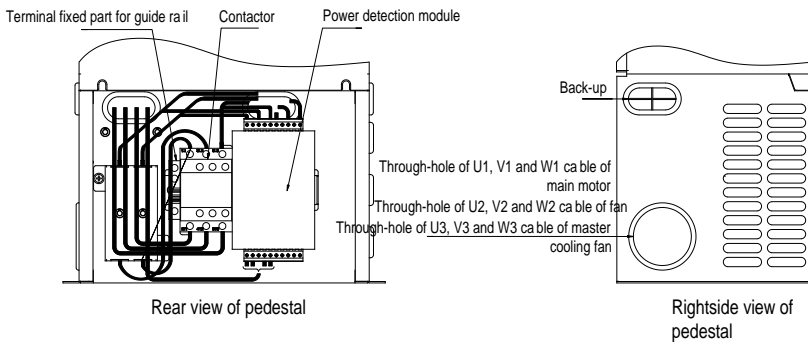

Fig B.18 Wiring diagram of the back of optional pedestal

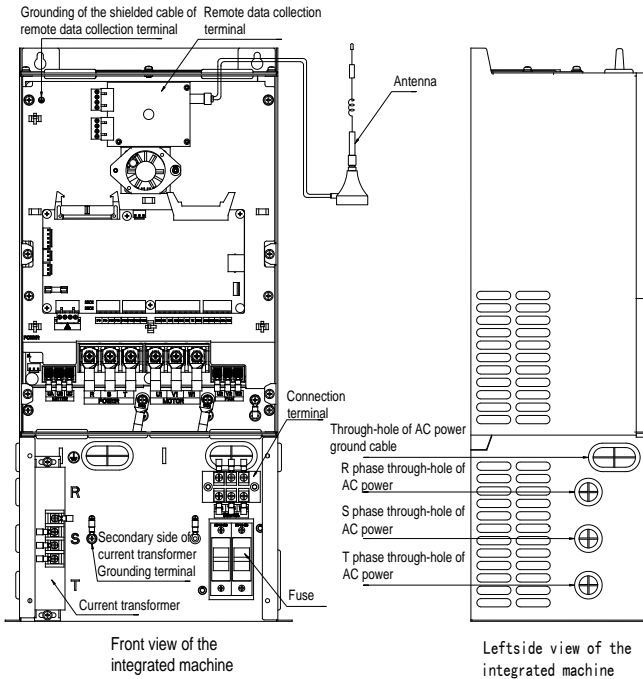

Fig B.19 Installation diagram of optional pedestal

B.6.5. Floor wiring process

For changing from wall installation to floor installation, an optional pedestal can do the trick.

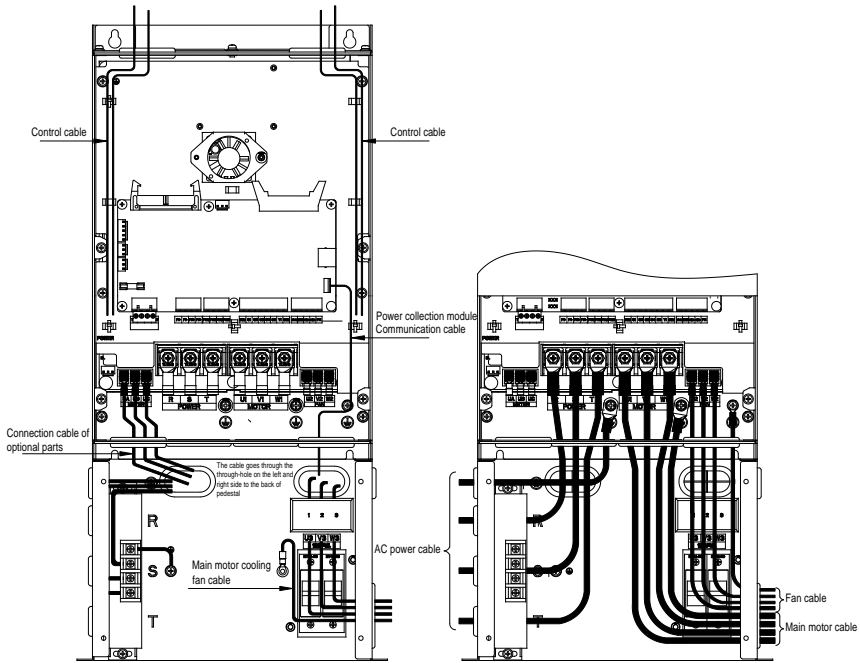

Fig B.20 Wiring diagram of control circuit and main circuit

Note: If the optional parts are not installed on the pedestal, the cable length may be inappropriate. Users can make cables based on actual conditions.

B.7. Touch screen

In respect of drive and management of air compressor, users can choose to install our VT6070E touch screen to match with Goodrive300-21. The touch screen package contains a 2m long RS485 communication cable (including 24V power cable) and signal wire for emergency-stop switch as shown below:

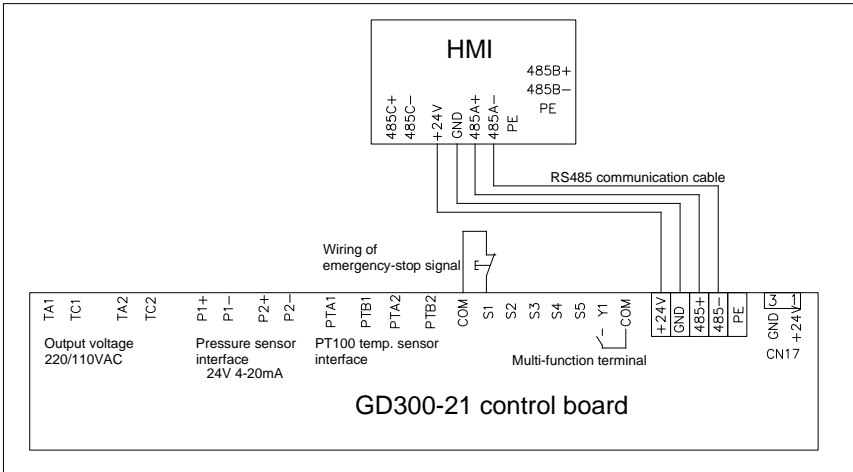

Fig B.21 Wiring of standard cable of touch screen

Note:

1. The RS485 communication cable of touch screen is non-shielded cable, shielded cable needs to be purchased separately.
2. Please refer to "Instruction manual for VT6070E series touch screen HMI" for detailed instruction on the touch screen.

Appendix C. Communication protocol

C.1. Application mode of the inverter

The Modbus protocol of the inverter is RTU mode and the physical layer is 2-wire RS485.

C.1.1. RS485

The interface of RS485 works on semiduplex and its data signal applies differential transmission which is called balance transmission, too. It uses twisted pairs, one of which is defined as A (+) and the other is defined as B (-). Generally, if the positive electrical level between sending drive A and B is among +2~+6V, it is logic“1”, if the electrical level is among -2V~-6V; it is logic“0”.

485+ on the terminal board corresponds to A and 485- to B.

Communication baud rate (P14.01) means the binary bit number transmitted in one second. The unit is bit/s (bps). The higher the baud rate, the quicker the transmission speed and the weaker the anti-interference ability. If the twisted pairs of 0.56mm (24AWG) is applied as the communication cables, the Max. Transmission distance is as below:

Baud rate	Max. transmission distance	Baud rate	Max. transmission distance
2400BPS	1800m	9600BPS	800m
4800BPS	1200m	19200BPS	600m

It is recommended to use shielded cables and make the shield layer as the grounding wires during RS485 remote communication.

In the cases with less devices and shorter distance, it is recommended to use 120Ω terminal resistor as the performance will be weakened if the distance increase even though the network can perform well without load resistor.

C.2. RTU command code and communication data illustration

C.2.1. Command code: 03H, read N words (the continuous reading is 16 words to the max.)

Command code 03H means that if the master read data from the inverter, the reading number depends on the “data number” in the command code. The max. Continuous reading number is 16 and the parameter address must be continuous. The byte length of every data is 2 (one word).

This command code is used to read the parameters and working stage of the inverter.

C.2.2. Command code: 06H, write one word

This command means that the master write data to the inverter and one command can write one data only other than multiple data. Its role is to change the parameters and working mode of the inverter.

C.2.3. Command code: 08H, diagnosis function

Meaning of sub-function codes

Sub-function Code	Description
0000	Return to inquire information data

C.2.4. Command code: 10H, continuous writing

Command code 10H means that if the master writes data to the inverter, the data number depends on the “data number” in the command code. The max. continuous reading number is 16.

C.2.5. The definition of data address

The address definition of the communication data in this part is to control the running of the inverter and get the state information and relative function parameters of the inverter.

C.2.5.1 The rules of parameter address of the function codes

The parameter address occupies 2 bytes with the high bit is in the front and the low bit in the behind. The range of high and low byte is: high byte—00–ffH; low byte—00–ffH. The high byte is the group number before the radix point of the function code and the low byte is the number after the radix point. But both the high byte and the low byte should be changed into hex. For example P05.06, the group number before the radix point of the function code is 05, then the high bit of the parameter is 05, the number after the radix point 06, then the low bit of the parameter is 06, then the function code address is 0506H and the parameter address of P10.01 is 0A01H.

C.2.5.2 The address instruction of other function in Modbus

This part is the address definition for communication data. It is used to control inverter operation, obtain inverter state information as well as relevant inverter parameter setting.

Table C.1 Other function parameters

Function instruction	Address definition	Data meaning instruction	R/W characteristic
Communication control command	2000H	0001H:forward running	R/W
		0002H:reverse running	
		0003H:forward jogging	
		0004H:reverse jogging	
		0005H:stop	
		0006H:coast to stop (emergency stop)	
		0007H:fault reset	
		0008H:jogging stop	
The address of the communication n setting value	2001H	Communication setting frequency(0–Fmax(unit: 0.01Hz))	R/W
	2002H	PID reference, range(0–1000, 1000 corresponds to100.0%)	R/W
	2003H	PID feedback, range(0–1000, 1000 corresponds to100.0%)	R/W
	2004H	Torque setting value (-3000–3000, 1000 corresponds to the 100.0% of the rated current of the motor)	R/W

Function instruction	Address definition	Data meaning instruction	R/W characteristic
	2005H	The upper limit frequency setting during forward rotation(0–Fmax(unit: 0.01Hz))	R/W
	2006H	The upper limit frequency setting during reverse rotation(0–Fmax(unit: 0.01Hz))	R/W
	2007H	The upper limit torque of electromotion torque (0–3000, 1000 corresponds to the 100.0% of the rated current of the motor)	R/W
	2008H	The upper limit torque of braking torque (0–3000, 1000 corresponds to the 100.0% of the rated current of the motor)	R/W
	2009H	Special control command word Bit0–1:=00:motor 1 =01:motor 2 =10:motor 3 =11:motor 4 Bit2:=1 torque control prohibit =0: torque control prohibit invalid Bit3: =1 power consumption clear =0: no power consumption clear Bit4: =1 pre-exciting =0: pre-exciting prohibition Bit5: =1 DC braking =0: DC braking prohibition	R/W
	200AH	Virtual input terminal command , range: 0x000–0x1FF	R/W
	200BH	Virtual input terminal command , range: 0x00–0x0F	R/W
	200CH	Voltage setting value(special for V/F separation) (0–1000, 1000 corresponds to the 100.0% of the rated voltage of the motor)	R/W
	200DH	AO output setting 1 (-1000–1000, 1000 corresponds to 100.0%)	R/W
	200EH	AO output setting 2 (-1000–1000, 1000 corresponds to 100.0%)	R/W
	200FH	BIT0:=1 Clear the working time of part 1 =0: invalid BIT1:=1 Clear the working time of part 2 =0: invalid BIT2:=1 Clear the working time of part 3 =0: invalid	R/W

Function instruction	Address definition	Data meaning instruction	R/W characteristic
		BIT4:=1 Clear the working time of part 5 =0: invalid BIT5:=1 Clear the working time of the device =0: invalid BIT6:=1 Solenoid valve loading =0: Solenoid valve unloading	
	2010H	The set time for maintenance on part 1; range: 0–65535	W
	2011H	The set time for maintenance on part 2; range: 0–65535	W
	2012H	The set time for maintenance on part 3; range: 0–65535	W
	2013H	The set time for maintenance on part 4; range: 0–65535	W
	2014H	The set time for maintenance on part 5; range: 0–65535	W
	2015H	Working time of part 1; 0–65535	W
	2016H	Working time of part 2; 0–65535	W
	2017H	Working time of part 3; 0–65535	W
	2018H	Working time of part 4; 0–65535	W
	2019H	Working time of part 5; 0–65535	W
	201AH	Running time of the device; 0–65535	W
	201BH	Command reference during fan debugging mode 0: No action 1: Running 2: Jogging 3: Stop 4: Coast to stop 5: Fault reset	R/W
	201CH	Frequency reference during fan debugging mode; range (0–1000, 1000 corresponds to 100.0%)	R/W
SW 1 of the inverter	2100H	0001H: forward running	R
		0002H: forward running	
		0003H: stop	
		0004H: fault	
		0005H: inverter POFF state	
		0006H: pre-exciting state	

Function instruction	Address definition	Data meaning instruction	R/W characteristic
SW 2 of the inverter	2101H	Bit0: =0:bus voltage is not established =1:bus voltage is established Bit1-2:=00:motor 1 =01:motor 2 =10:motor 3 =11:motor 4 Bit3: =0:asynchronous motor =1:synchronous motor Bit4:=0:no overload pre-alarm; =1:overload pre-alarm Bit5- Bit6:=00: keypad control =01:terminal control =10:communication control	R
Fault code of the inverter	2102H	See the fault type instruction	R
Identifying code of the inverter	2103H	GD300-21-----0x0129	R
Operation frequency	3000H	Compatible with communication address of CHF100A, CHV100	R
Setting frequency	3001H		R
Bus voltage	3002H		R
Output voltage	3003H		R
Output current	3004H		R
Operation speed	3005H		R
Output power	3006H		R
Output torque	3007H		R
Close loop setting	3008H		R
Close loop feedback	3009H		R
PID setting	3008H		R
PID feedback	3009H		R
Input IO	300AH		R
Input IO	300BH		R
AI 1	300CH		R
AI 2	300DH		R
AI 3	300EH		R
AI 4	300FH		R
Read high speed pulse 1 input	3010H		R

Function instruction	Address definition	Data meaning instruction	R/W characteristic
Read high speed pulse 2 input	3011H		R
Read current step of the multi-step speed	3012H		R
External length	3013H		R
External counting value	3014H		R
Torque setting	3015H		R
Inverter code	3016H		R
Fault code	5000H		R

C.2.6. Fault message response

Table C.2 Code and definition for fault message response

Code	Name	Meaning
01H	Illegal command	The command from master cannot be executed. The reason maybe: 1.This command is only for new version and this version cannot realize. 2. Slave is in fault state and cannot execute it.
02H	Illegal data address.	Some of the operation addresses are invalid or not allowed to access. Especially the combination of the register and the transmitting bytes are invalid.
03H	Illegal value	When there are invalid data in the message framed received by slave. Note: This error code does not indicate the data value to write exceed the range, but indicate the message frame is an illegal frame.
04H	Operation failed	The parameter setting in parameter writing is invalid. For example, the function input terminal cannot be set repeatedly.
05H	Password error	The password written to the password check address is not same as the password set by P7.00.
06H	Data frame error	In the frame message sent by the upper PC, the length of the digital frame is incorrect or the counting of CRC check bit in RTU is different from the lower monitor.
07H	Written not allowed.	
08H	The parameter cannot be modified during running	The modified parameter in the writing of the upper PC cannot be modified during running.
09H	Password	When the upper PC is writing or reading and the user password is set

Code	Name	Meaning
	protection	without password unlocking, it will report that the system is locked.

The slave uses functional code fields and fault addresses to indicate it is a normal response or some error occurs (named as objection response). For normal responses, the slave shows corresponding function codes, digital address or sub-function codes as the response. For objection responses, the slave returns a code which equals the normal code, but the first byte is logic 1.

For example: when the master sends a message to the slave, requiring it to read a group of address data of the inverter function codes, there will be following function codes:

0 0 0 0 0 0 1 1 (Hex 03H)

For normal responses, the slave responds the same codes, while for objection responses, it will return:

1 0 0 0 0 0 1 1 (Hex 83H)

Besides the function codes modification for the objection fault, the slave will respond a byte of abnormal code which defines the error reason. When the master receives the response for the objection, in a typical processing, it will send the message again or modify the corresponding order.

Appendix D. Common EMC problems and countermeasures

D.1. Interference problems of meter switch and sensors

Interference phenomena:

The sensor signal (pressure, temperature, displacement, etc) is collected and displayed via HMI device, the sensor value displayed after inverter starts is wrong, the common errors are listed as below:

- Incorrect display of upper limit or lower limit value, such as 999 or -999;
- The displayed value changes randomly (often occurred to pressure transmitter);
- The displayed value is stable but huge deviation exists eg the displayed temperature value is dozens of centigrade higher than the normal value (often occurred to thermocouple);
- The signal collected by the sensor does not display directly but act as feedback signal for drive system operation eg the inverter starts to decelerate once air compressor has reached the upper limit pressure, however, actually the inverter starts to decelerate before upper limit pressure is reached;
- Various meters connected by inverter analog output (AO) (such as frequency meter, current meter, etc), the value displayed by these meters after inverter starts is inaccurate;
- The system adopts proximity switch. The indicator of proximity switch flickers after inverter starts, overturn occurred to output level by mistake.

Solution

- Check and confirm the sensor feedback line is routed with motor cable at a distance of at least 20cm;
- Check and ensure motor ground line has been connected to PE terminal of the inverter (if motor ground line has been connected to the grounding bar of inverter cabinet, measure with multimeter to confirm that the resistance between grounding bar and PE terminal is less than 1.5Ω);
- If there are too many interfered meters/sensor, it is recommended to install external C2 filter at the input power side of the inverter.

D.2. 485 communication interference

The 485 communication interference mainly lies in communication delay, out of sync, disconnection or occasional normal after inverter starts.

Abnormal communication is not always caused by interference, which can be ruled out by below means:

- Check if circuit break or poor contact occurred to 485 communication bus;

- Check if the ends of A, B cable of the 485 communication bus are connected reversely.
- Check if the communication protocol (eg baud rate, data bit check, etc)of the inverter is in consistent with that of the upper PC;

If it is confirmed that the abnormality is caused by interference, rule out the problem cause by below means:

- The communication cable cannot be routed with motor cable in the same cable tray;
- In multi-machine application, the connection of inverter communication cables should adopt chrysanthemum mode to improve anti-interference ability;
- In multi-machine application, it is necessary to confirm that the drive capacity of the master is strong enough;
- For multi-machine connection, both ends should be connected with 120Ω terminal resistors.

Solution:

- Check and confirm the motor ground line is connected to PE terminal of the inverter (if motor ground line has been connected to the grounding bar of inverter cabinet, measure with multimeter to confirm that the resistance between grounding bar and PE terminal is less than 1.5Ω);
- Inverter and motor cannot be common grounded with upper PC of communication (PLC, HMI, touch screen, etc). It is recommended to connect the inverter and motor with power GND while the upper PC of communication should be connected to the ground pile separately;
- Try to short circuit reference GND of inverter signal with the reference GND of upper PC controller signal to ensure the ground potential of their communication chips is the same;
- Try to short circuit reference GND of inverter signal with grounding terminal (PE) of the inverter.

D.3. Unstoppable or shimmering indicator caused by coupling of motor cable

Interference phenomena:

- Unable to stop

For inverter system whose start/stop is controlled by S terminal, the motor cable and control cable are routed in the same cable tray. After system starts, it cannot stop via S terminal.

- Shimmering indicator

After inverter starts to run, shimmering, flickering or abnormal noise occurred to below devices:

- a) Relay indicator
- b) Indicator of distribution box
- c) PLC indicator

d) Indicating buzzer

Solution:

- Check and confirm the abnormal signal cable is routed with motor cable motor cable at a distance of at least 20cm;
- Connect in parallel the digital input terminal (S) used for start/stop control with other idle digital input terminals. For instance, S1 terminal is used for start/stop control, S4 terminal is idled, then try to short circuit S1 terminal with S4 terminal.

D.4. Leakage current and residual current device (RCD)

As the inverter outputs high frequency PWM voltage to drive the motor, the distributed capacitance against radiator from internal IGBT and between rotor and stator of the motor may cause the inverter to generate high frequency leakage current against the ground. While the RCD is used to detect the power frequency leakage current when grounding fault occurred to electrical circuit, the application of inverter may cause mal-operation of RCD.

How to select RCD:

Due to the specialty of inverter system, it is required that the rated residual operating current should be above 200mA for regular RCDs at all levels, and the inverter must be grounded with proper technics.

As for the setting time of RCD, the time limit of preceding action should be longer than the secondary action and time gap between them should be set to a value larger than 20ms eg 1s, 0.5s and 0.2s.

It is recommended to use electromagnetic RCD for the electrical circuit of inverter system. Such RCD carries strong anti-interference capacity to prevent the RCD from being affected by high frequency leakage current.

Electronic RCD	Electromagnetic RCD
Low cost, high sensitivity, small size, vulnerable to voltage fluctuation of the grid and ambient temperature, weak anti-interference capacity	Require the zero sequence current transformer to be quite sensitive, precise and stable, made from permalloy material with high permeability, complicated process and high cost, immune to voltage fluctuation of the grid and ambient temperature, strong anti-interference capacity

Solution to mal-operation of RCD (on the part of inverter)

- Try to disassemble the jumper cap in “EMC/J10” (refer to chapter 2.1.1 for the position of J10 jumper)
- Try to decrease the carrier frequency to 1.5kHz (P00.14=1.5);
- Try to change the modulation mode to “3-phase modulation and two-phase modulation” (P8.40=00)

Solution to mal-operation of RCD (on the part of system distribution)

- a) Check and confirm the power cable is not immersed in water
- b) Check and confirm the cable is not broken or switched over;
- c) Check and confirm if secondary grounding occurred to the null line;
- d) Check and confirm if power cable terminal is in the air switch or the contactor is poorly contacted (loose screws);
- e) Check the single-phase electric equipment and confirm if the ground line is misused as null line;
- f) Inverter power cable and motor cable should not be shielded ones.

Leakage protection of motor autotuning

During motor autotuning, the measurement on differing motor parameters is conducted step by step, in which the first two steps is to measure the resistance of motor stator/rotor while the inverter will output square wave to motor stator winding at 4kHz (default carrier frequency), as leakage current generated by 4kHz carrier frequency against distributed capacitance between motor rotor and stator during charging/discharging is quite obvious, which may cause mal-operation of RCD. If such problem occurred, bypass RCD first and restore after parameter autotuning is completed.

D.5. Problem of charged device shell

The problem mainly lies in that the device shell carries detectable voltage which gives anyone who touches it a feeling of electrical shock, however, when the inverter is powered up without running, the shell will be uncharged (or the voltage it carries is far lower than human body safety voltage).

Solution:

- a) If there is distribution grounding or ground pile on users' site, grounding the shell of inverter cabinet by power GND or ground pile;
- b) If there is no ground connection on site, it is necessary to electrically connect the motor shell to grounding terminal PE of the inverter and confirm that the jumper in "EMC/J10" of the inverter is short circuited (refer to chapter 2.1.2 for the position of EMC/J10 jumper).



Service line: 86-755-23535967 E-mail: overseas@invt.com.cn Website: www.invt.com

The products are owned by **Shenzhen INVT Electric Co., Ltd.**

Two companies are commissioned to manufacture: (For product code, refer to the 2nd/3rd place of S/N on the name plate.)

Shenzhen INVT Electric Co., Ltd. (origin code: 01)

Address: INVT Guangming Technology Building, Songbai Road,
Matian, Guangming District, Shenzhen, China

INVT Power Electronics (Suzhou) Co., Ltd. (origin code: 06)

Address: 1# Kunlun Mountain Road, Science&Technology Town,
Gaixin District, Suzhou, Jiangsu, China

- Industrial Automation:** ■ HMI ■ PLC ■ VFD ■ Servo System
 ■ Elevator Intelligent Control System ■ Rail Transit Traction System
- Energy & Power:** ■ UPS ■ DCIM ■ Solar Inverter ■ SVG
 ■ New Energy Vehicle Powerstain System ■ New Energy Vehicle Charging System
 ■ New Energy Vehicle Motor



66001-00485

Copyright© INVT.

Manual information may be subject to change without prior notice.

201912 (V1.4)